



# Axiom

## Audio Extension I/O Modules



## User Manual

Date 2/21/2020

1675 MacArthur Boulevard · Costa Mesa, CA 92626  
Ph: 800/854-4079 or 714/957-7100 · Fax: 714/754-6174

© 2020 QSC, LLC all rights reserved. QSC and the QSC logo are registered trademarks of QSC, LLC in the U.S. Patent and Trademark office and other countries. All other trademarks are the property of their respective owners. Patents may apply or be pending.

[www.qsc.com](http://www.qsc.com)

614-0006363

## IMPORTANT SAFETY INSTRUCTIONS

The symbols below are internationally accepted symbols that warn of potential hazards with electrical products.



This symbol, wherever it appears, alerts you to the presence of un-insulated dangerous voltage inside the enclosure -- voltage that may be sufficient to constitute a risk of shock.



This symbol, wherever it appears, alerts you to important operating and maintenance instructions in the accompanying literature. Please read the manual.

1. Read these instructions.
2. Keep these instructions.
3. Heed all warnings.
4. Follow all instructions.
5. Do not use this apparatus near water.
6. Clean only with a dry cloth.
7. Do not block any ventilation openings. Install in accordance with the manufacturer's instructions.
8. Do not install near any heat sources such as radiators, heat registers, stoves, or other apparatus (including amplifiers) that produce heat.
9. Do not defeat the safety purpose of the polarized or grounding-type plug. A polarized plug has two blades with one wider than the other. A grounding type plug has two blades and third grounding prong. The wider blade or the third prong is provided for your safety. If the provided plug does not fit into your outlet, consult an electrician for replacement of the obsolete outlet.
10. Protect the power cord from being walked on or pinched particularly at plugs, convenience receptacles, and the point where they exit from the apparatus.
11. Only use attachments/accessories specified by Attero Tech
12. Use only with the cart, stand, tripod, bracket, or table specified by the manufacturer, or sold with the apparatus.
13. Unplug this apparatus during lightning storms or when unused for long periods of time.
14. Refer all servicing to qualified service personnel. Servicing is required when the apparatus has been damaged in any way, such as power-supply cord or plug is damaged, liquid has been spilled or objects have fallen into the apparatus, the apparatus has been exposed to rain or moisture, does not operate normally, or has been dropped.
15. When permanently connected, on all-pole mains switch with a contact separation of at least 3mm in each pole shall be incorporated in the electrical installation of the building.
16. If rack mounting, provide adequate ventilation. Equipment may be located above or below this apparatus but some equipment (like large power amplifiers) may cause an unacceptable amount of hum or may generate too much heat and degrade the performance of this apparatus.



TO REDUCE THE RISK OF FIRE OR ELECTRIC SHOCK, DO NOT EXPOSE THIS APPARATUS TO RAIN OR MOISTURE.

## WARRANTY INFORMATION

For a copy of the QSC Limited Warranty, visit the QSC website at [www.qsc.com](http://www.qsc.com)

Note: This equipment has been tested and found to comply with the limits for a Class A digital device, pursuant to Part 15 of the FCC Rules and EN55022. These limits are designed to provide reasonable protection against harmful interference when the equipment is operated in a commercial environment. This equipment generates, uses, and can radiate radio frequency energy and, if not installed and used in accordance with the instruction manual, may cause harmful interference to radio communications. Operation of this equipment in a residential area is likely to cause harmful interference, in which case the user will be required to correct the interference at their own expense.





## Contents

<b>1 - Axiom Bus Overview .....</b>	<b>1</b>
<b>2 - ML1 - Overview.....</b>	<b>1</b>
- ML1 - What's in the Box .....	1
- ML1 - Device Installation .....	2
ML1 - Mounting .....	2
- ML1 - Signal Metering LED Indications .....	1
- ML1 - Controls .....	1
- ML1 - Device Config & Workflow Overview .....	1
<b>3.1- USB1 - Overview.....</b>	<b>2</b>
2.2	
2.2.1 - USB1 - What's in the Box .....	2
2.2.2 - USB1 - Device Installation .....	2
2.2.3	
2.2.4	
USB1 - Mounting .....	2
- USB1 - Status LEDs .....	1
- USB1 - USB Audio Modes .....	1
- Device Config & Workflow Overview .....	1
3.1	
3.2	
3.2.1	
3.2.2	
3.2.3	
3.2.4	
<b>4 - BT1 - Overview .....</b>	<b>2</b>
- BT1 - What's in the Box .....	2
- BT1 - Device Installation .....	2
BT1 - Mounting .....	2
- BT1 - Status LEDs .....	3
- BT1 - Device Config & Workflow .....	3
- BT1 - Device Settings .....	3
- Bluetooth® Pairing/Connect Modes .....	3
4.3.1	
4.3.1.1 - Manual Mode .....	3
4.3.1.2 - Reconnect Mode .....	3
4.3.1.3 - Exclusive Mode .....	3
4.3.2	
- Bluetooth® Audio Bridging .....	4
4.3.2.1 - Media Bridging (only) .....	4
4.3.2.2 - Call Bridging (only) .....	4
4.3.3	
4.3.2.3 - Call & Media Bridging .....	4
- Bluetooth® Pass-through AVRCP (AV Remote Control Protocol) .....	4
5.1	
5.2	
<b>5 - AXP20 - Overview.....</b>	<b>5</b>
5.3	
5.4	
5.5	
- AXP20 - What's in the Box .....	5
- AXP20 - Device Installation .....	6
- Mounting .....	6
- Audio Connections .....	7
- 3 <sup>rd</sup> Party Control .....	7
- RS-232 Interface .....	7
6.1	
6.1.1	
<b>6 - AXPio - Overview .....</b>	<b>8</b>
6.1.3	
- AXPio - What's in the Box .....	8
6.1	
6.1.1 - USB1 - Device Installation .....	8
6.1.2 - Mounting .....	9
6.2	
6.3	
Hardware Connections .....	10
- Balanced to Balanced Wiring .....	10
- Balanced to Unbalanced Wiring .....	10
- Unbalanced to Balanced Wiring .....	10
- Audio Configuration .....	11
- Input Settings .....	11
- Output Settings .....	11
- 3 <sup>rd</sup> Party Control .....	11
- RS-232 Interface .....	11
<b>ARCHITECTS &amp; ENGINEERS SPECIFICATION .....</b>	<b>1</b>
ML1 .....	1
USB1 .....	1
BT1 .....	1
AXP20 .....	2
AXPio .....	2



<b>Device Specifications</b> .....	<b>iii</b>
ML1 Specs.....	iii
USB1 Specs.....	iii
BT1 Specs.....	iv
AXP20 Specs.....	iv
AXPio Specs.....	v

## 1 - Axiom Bus Overview

The Attero Tech Axiom bus is a proprietary analog extension solution that leverages unshielded twisted pair cabling (CAT 5/6) to transmit two balanced audio channels, RS-232 control and 24V DC power for audio signal extension applications.

The Axiom bus is designed to support distances of up to 100m (total run length). The Axiom bus also supports daisy chain connectivity of up to two Axiom devices to provide flexible modularity for various audio device connectivity in installed AV systems.

8P8C Pin	TIA 568A Pair: Color	TIA 568B Pair: Color	Axiom Port Function
1	3: Green/White	2: Orange/White	Analog Audio 1+
2	3: Green	2: Orange	Analog Audio 1-
3	2: Orange/White	3: Green/White	Analog Audio 2+
4	1: Blue	1: Blue	RS-232 TXD)
5	1: Blue/White	1: Blue/White	RS-232 RXD
6	2: Orange	3: Green	Analog Audio 2-
7	4: Brown/White	4: Brown/White	+24 VDC
8	4: Brown	4: Brown	GND

Table 1 - Axiom Bus Details

## Application Diagram

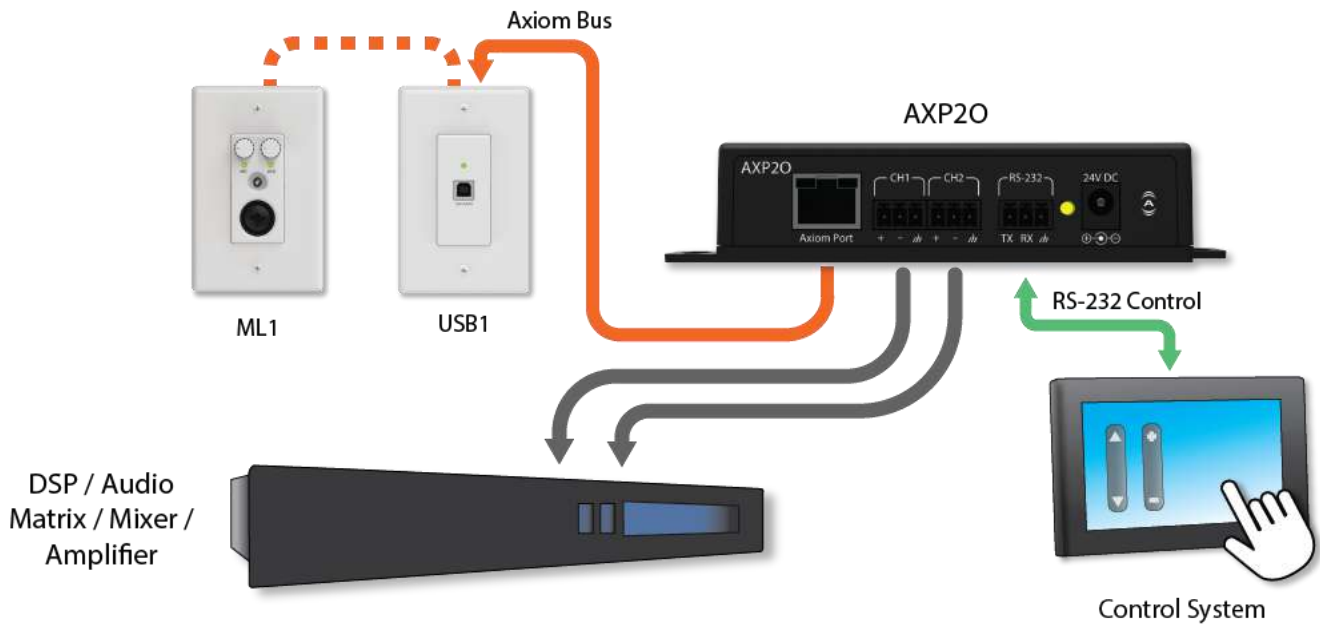

Figure 1 - Axiom Bus Application

## 2- ML1 - Overview



**Figure 2 - ML1 Front Panel**

The Axiom ML1 provides an installation friendly simple to operate analog audio extension solution for analog mic and line level sources in cost-sensitive applications such as small and medium sized retail, restaurant, education, and hospitality venues.

### - ML1 - What's in the Box

2.1 The ML1 comes supplied with the following:

- Axiom ML1 device
  - Includes interchangeable white and black Decora-style inserts
- (1) White US Single Gang Decora® cover plate w/screws
- (1) Black US Single Gang Decora® cover plate w/screws
- (2) Wall plate mounting screws

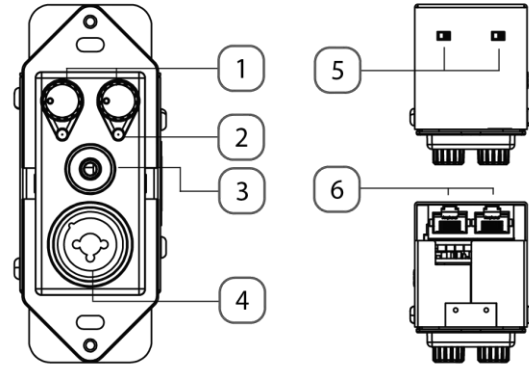

**Figure 3 - Product Overview**

ID	Description
1	Gain Adjust Knobs
2	Signal Presence Indicators
3	3.5mm Input
4	XLR/TRS Input (1/4" TRS Padded for +20dBu support)
5	Axiom Port A Configuration Switches
6	Axiom Ports (A & B)

**- ML1 - Device Installation**

**ML1 - Mounting**

A typical installation will involve mounting the wall plate into a pre mounted wall box or mounting bracket. Before installation, make sure the wall box where the ML1 is to be installed is pre-wired with a suitable cable back to an Axiom-enabled expander/injector.

- 2.2
- 2.3 Prior to ML1 installation, ensure the power sourcing device (Axiom expander/injector) is powered off.

Attach and unshielded CAT-5/6 cable from the Axiom-enabled device to the Axiom port A of the ML1.

With the cable attached, carefully place the ML1 into the wall box taking care to not trap the cabling. Once in place, secure it with the screws provided. Once the unit is secured in the wall box, fit the Decora plate and secure it with the screws provided.

Now you may apply power to the Axiom-enabled expander/injector, the unit will power up and the signal presence LEDs should blink once quickly.

The ML1 comes in a single gang US Decora style form factor and may be mounted in most US single old and new work back boxes and mud-rings. Given the single gang size, the ML1 may be mounted in larger gang boxes with other single gang form factor products to provide flexible AV system modularity where needed.

*\*Note: CAD drawings can be downloaded from the QSC website. Please contact Attero Tech for any further product related information that is not accessible on the website.*

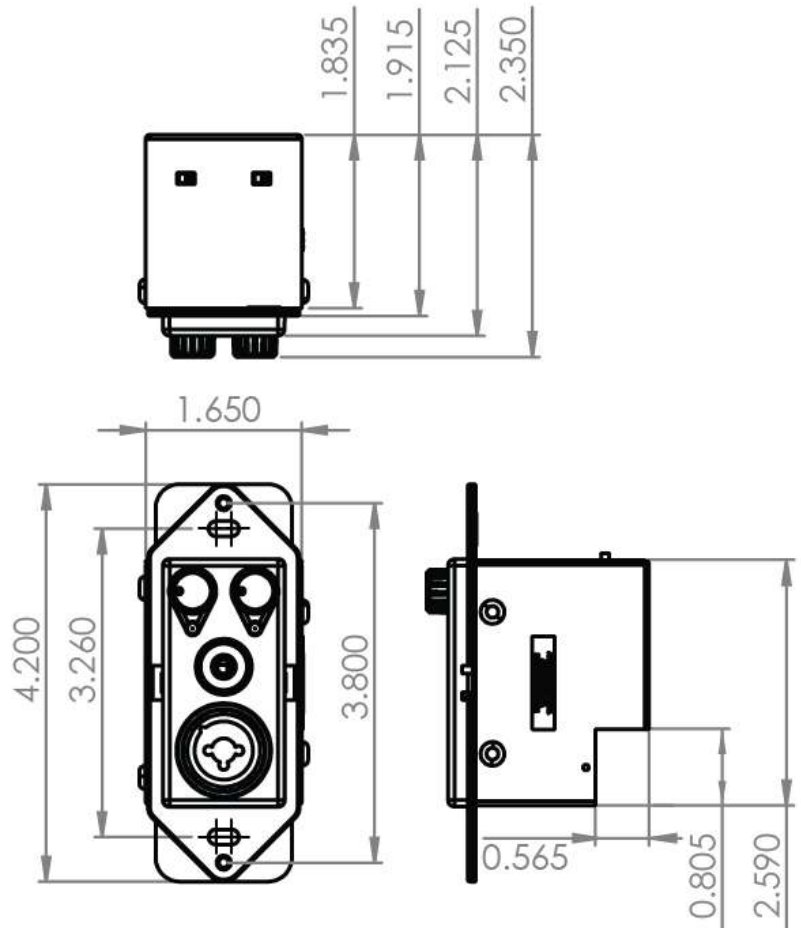

Figure 4 - Dimensional Drawing



**- ML1 - Signal Metering LED Indications**

The ML1 is equipped with two LED indicators below the rotary encoders for each the 1/4" XLR Mic input and the 3.5mm line input. The following chart indicates the available LED status information:



Figure 5 - LED Signal Metering

LED State	Status
Off	No signal present
Green	-60 dBFS to < -20 dBFS
Yellow/Amber	-20 dBFS to < -3 dBFS
Red	-3 dBFS to 0 dBFS

**Note:** The full scale output of the Axiom bus is optimized for +20dBu levels, so 0dBFS in terms of metering refers to +20 dBu

2.2.3 **- ML1 - Controls**

The ML1 controls the desired input gain simply using the coinciding input knob (see Figure 4). Turning the knob clockwise raises the level, while counter-clockwise lowers.

2.2.4 **- ML1 - Device Config & Workflow**

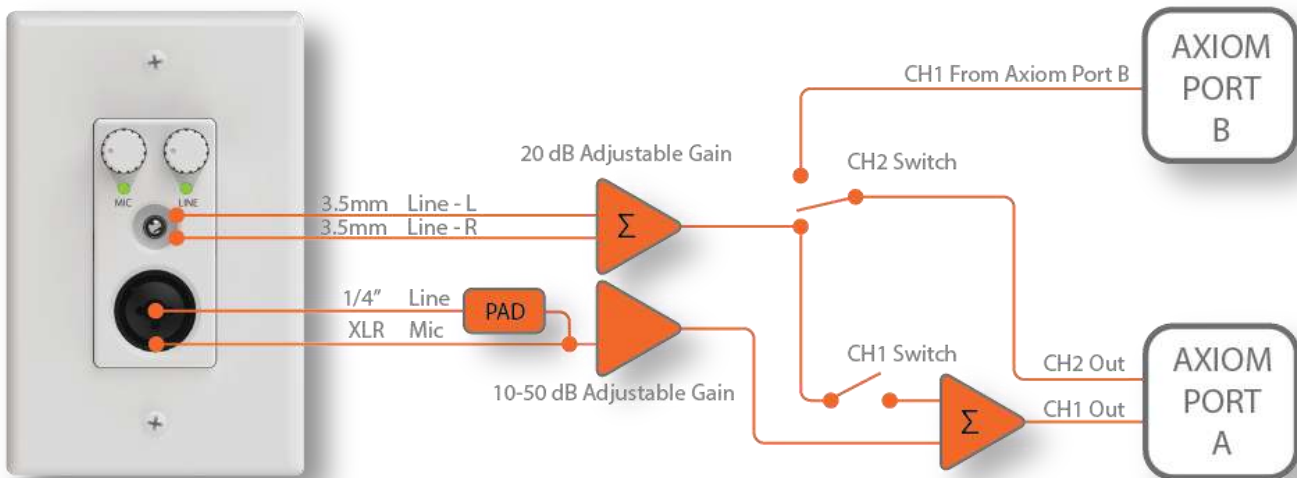

Figure 6 - Signal Flow

**Overview**

The ML1 may be configured for single use, or daisy-chained with one other Axiom device.

The default configuration is for single device use with Port B disabled and XLR enabled.

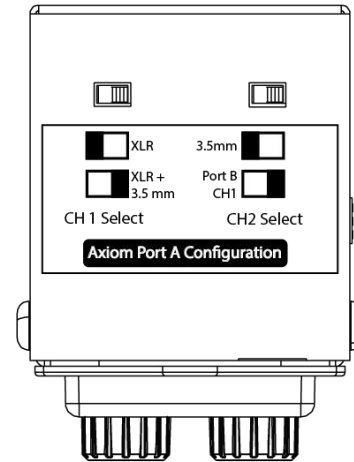

Figure 7 - Switch Label/Config Options

The CH1 Select switches allows the integrator to route either the XLR or a sum of the XLR and 3.5mm inputs to the CH1 output of Axiom Port A.

The CH2 Select allows the integrator to route either the 3.5mm input or the Axiom Port CH1 (daisy chained Axiom device) to the CH2 output of Axiom Port A.

### 3- USB1 - Overview



Figure 8 - USB1 Front Panel

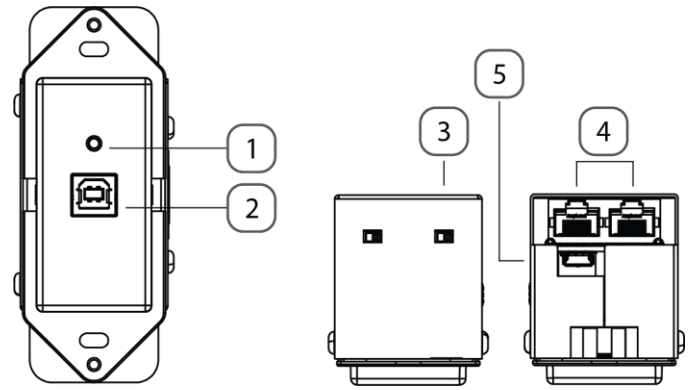

Figure 9 - Product Overview

The Axiom USB1 provides bidirectional USB audio connectivity for education, corporate or hospitality applications. Connect a PC or music content server to interface your device's USB audio content with the room's audio system. The USB1 also offers BYOD (bring-your-own-device) support, allowing users to connect their laptops to integrate the room's audio into their web conferencing application (Microsoft Teams, Zoom, etc).

#### 3.1 - USB1 - What's in the Box

The USB1 comes supplied with the following:

- Axiom USB1 device
- Includes interchangeable white and black Decora-style inserts
- (1) White US Single Gang Decora® cover plate w/screws
- (1) Black US Single Gang Decora® cover plate w/screws
- (2) Wall plate mounting screws

ID	Description
1	Status LED
2	USB Type B Port
3	Axiom Port Configuration Switch
4	Axiom Ports (A & B)
5	Mini-USB Configuration Port

**- USB1 - Device Installation**  
**USB1 - Mounting**

A typical installation will involve mounting the wall plate into a pre mounted wall box or mounting bracket. Before installation, make sure the wall box where the USB1 is to be installed is pre-wired with a suitable cable back to an Axiom-enabled expander/injector.

- 3.2
3. Prior to USB1 installation, ensure the power sourcing device (Axiom expander/injector) is powered off.

Attach and unshielded CAT-5/6 cable from the Axiom-enabled device to the Axiom port A of the USB1.

With the cable attached, carefully place the USB1 into the wall box taking care to not trap the cabling. Once in place, secure it with the screws provided. Once the unit is secured in the wall box, fit the Decora plate and secure it with the screws provided.

Now you may apply power to the Axiom-enabled expander/injector, the unit will power up and the signal presence LEDs should blink once quickly.

The USB1 comes in a single gang US Decora style form factor and may be mounted in most US single old and new work back boxes and mud-rings. Given the single gang size, the USB1 may be mounted in larger gang boxes with other single gang form factor products to provide flexible AV system modularity where needed.

*\*Note: CAD drawings can be downloaded from the QSC website. Please contact QSC for any further product related information that is not accessible on the website.*

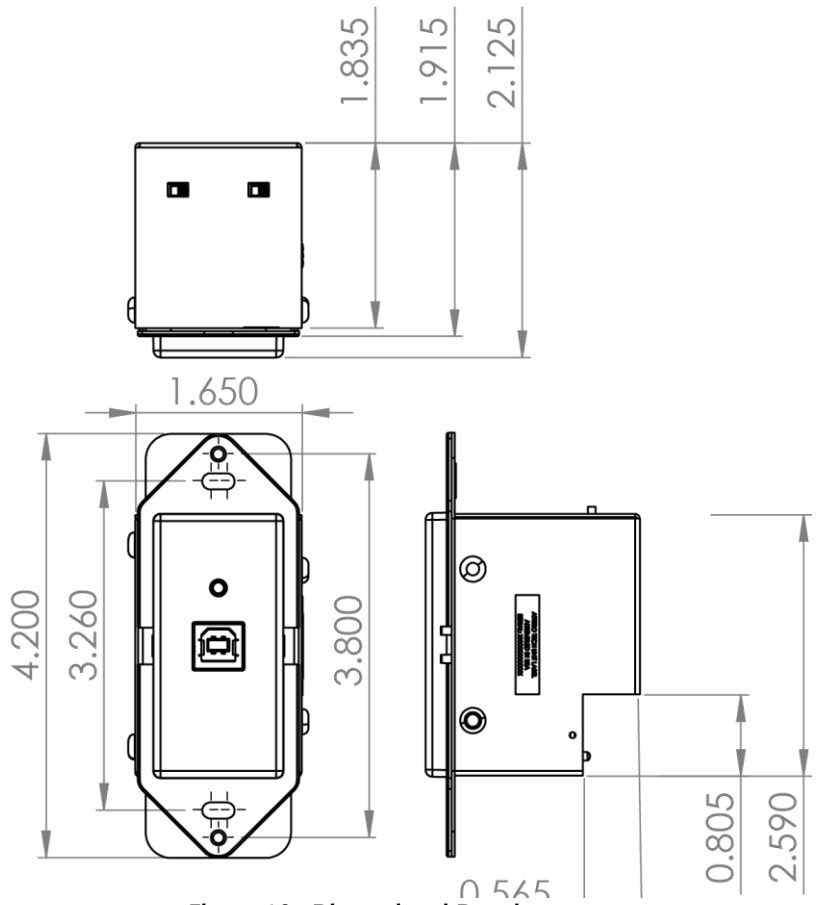

Figure 10 - Dimensional Drawing

### - USB1 – Status LEDs

The USB1 is equipped with a single LED indicator above the USB port. The following chart indicates the available LED status information:

LED State	Status
Off	No power/boot
Blinking Green	Booting
Green	Normal Powered State
Blinking Yellow	Identify
Blinking Red	Muted

### - Device Config & Workflow Overview

The USB1 may be configured for single use, or daisy-chained with one other Axiom device.

The default configuration is for single device use with Port B disabled and Ch2 transmitting via Port A.

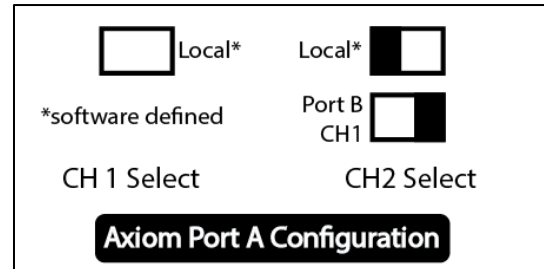

Figure 11 – Switch/Label Config Options

### - USB1 – USB Audio Modes

The USB1 supports 16-bit/48 kHz audio with three configurable sound card options with which the USB audio interface will declare itself.

- 1x1 Speakerphone (no host AEC)
- 1x1 Speakerphone (host AEC)
- 2x0/1x0 Line in/Line out

USB audio will be routed through the following Axiom ports based on each corresponding audio mode. Modes are set using unIFY Control Panel.

Mode	Axiom Pair A	Axiom Pair B
1 x 1 Play/Record	USB Playback Mono	USB Record Mono
2 x 0 Play Only	USB Playback Left	USB Playback Right
1 x 0 Play Only	USB Playback Mono	N/A

## 4 - BT1 - Overview



Figure 12 - USB1 Front Panel

The Axiom BT1 provides two-way Bluetooth connectivity and a 3.5 mm stereo audio connector, allowing users to easily connect consumer-grade devices to the room's audio system for music playback or Bluetooth conference call bridging.

### - BT1 - What's in the Box

4.1 The BT1 comes supplied with the following:

- Axiom BT1 device
- Includes interchangeable white and black Decora-style inserts
- (1) White US Single Gang Decora® cover plate w/screws
- (1) Black US Single Gang Decora® cover plate w/screws
- (2) Wall plate mounting screws

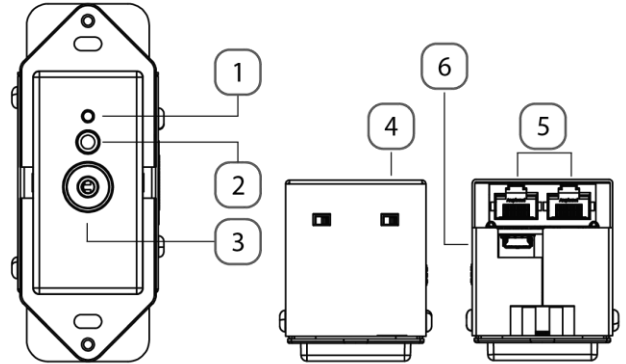

Figure 13 - Product Overview

ID	Description
1	Status LED
2	Pairing Button
3	1/8" Line Input
4	Axiom Port Configuration Switch
5	Axiom Ports (A & B)
6	Mini-USB Configuration Port

**- BT1 - Device Installation**  
**BT1 - Mounting**

A typical installation will involve mounting the wall plate into a pre mounted wall box or mounting bracket. Before installation, make sure the wall box where the BT1 is to be installed is pre-wired with a suitable cable back to an Axiom-enabled expander/injector.

- 4.2
- 4.3 Prior to USB1 installation, ensure the power sourcing device (Axiom expander/injector) is powered off.

Attach and unshielded CAT-5/6 cable from the Axiom-enabled device to the Axiom port A of the USB1.

With the cable attached, carefully place the BT1 into the wall box taking care to not trap the cabling. Once in place, secure it with the screws provided. Once the unit is secured in the wall box, fit the Decora plate and secure it with the screws provided.

Now you may apply power to the Axiom-enabled expander/injector, the unit will power up and the signal presence LEDs should blink once quickly.

The BT1 comes in a single gang US Decora style form factor and may be mounted in most US single old and new work back boxes and mud-rings. Given the single gang size, the BT1 may be mounted in larger gang boxes with other single gang form factor products to provide flexible AV system modularity where needed.

*\*Note: CAD drawings can be downloaded from the QSC website. Please contact QSC for any further product related information that is not accessible on the website.*

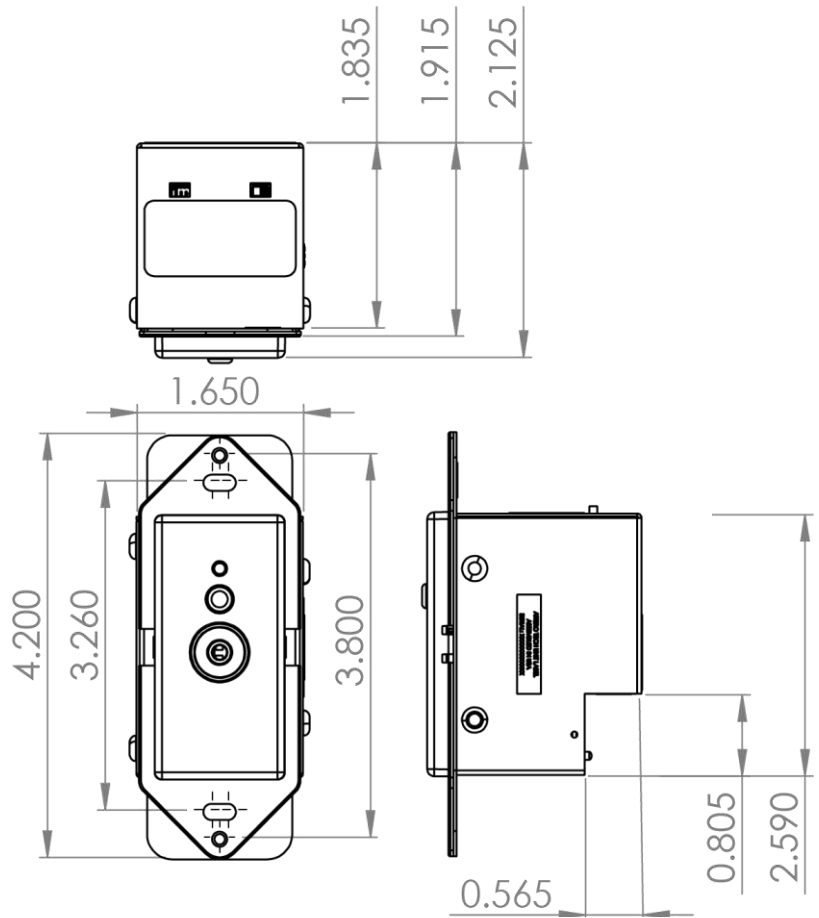

Figure 14 - Dimensional Drawing

## - BT1 - Status LEDs

The BT1 is equipped with a single LED indicator above the pairing button. The following chart indicates the available LED status information:

LED State	Status
White	Idle <span style="float: right;">4.3</span>
Flashing Blue	Discoverable/Pairing Mode
Blue	Connected
Red	Initializing <span style="float: right;">4.3.1</span>
Green	AUX jack connection detected
Flashing White	Identify
Flashing Purple	RSSI value of active Bluetooth® ≤ -90

## - BT1 - Device Config & Workflow

The BT1 may be configured for single use, or daisy-chained with other Axiom device.

The default configuration is for single device use with Port B disabled and Ch2 transmitting via Port A.

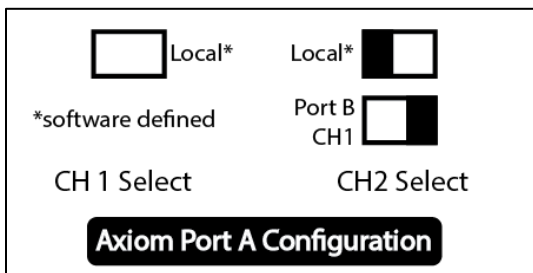

Figure 15 - Switch/Label Config Options

## - BT1 - Device Settings

The BT1 is designed use in a number of configurable modes to facilitate comprehensive use in professional AV applications. The following sections describe the available modes and their functionality.

### - Bluetooth® Pairing/Connect Modes

#### 4.3.1.1 - Manual Mode

This usage model is intended for applications where casual users of a public venue (sports bar, spa, stadium luxury box, fitness center) have access to connect their devices to the audio system but headaches are minimized by eliminating automatic reconnect and pairing history features.

In this mode, users connect their Bluetooth® audio enabled smart device by simply pressing the front panel “PAIR” button. The status LED will begin flashing blue to indicate that the BT1 is now visible to other Bluetooth® devices and accepting pairings. This pairing period lasts 60 seconds after which the status LED will stop flashing and turn off and the BT1 will disable its Bluetooth® interface.

*\*Note: The default Bluetooth friendly name visible to other devices is “BT1-xx:xx:xx”. This name can be customized by the installer using the unIFY Control Panel software.*

If a successful pairing is made during the pairing period, the status LED will stop flashing and turn constantly on.

To disconnect a Bluetooth device from the BT1, press and hold the PAIR button for 5 seconds and then release it. The status LED will turn off, and the connection will be reset. Another device may now be connected by repeating the pairing process.

#### 4.3.1.2 - Reconnect Mode

In this mode, the BT1 maintains a pool of the last 10 paired devices and any previously paired device on that list will be permitted to reconnect when in range of the BT1 without requiring the front panel button to be pressed. The user simply selects the BT1 friendly name on their smart device.

Any new devices that are paired are added to the paired device list. If the list already full, a random device from the list will be removed and the new device added in its place.

#### 4.3.1.3 - Exclusive Mode

This mode is intended for restricted/personal use and works similarly in operation to reconnect mode. However, rather than allow any known device from the pairing list to reconnect, only a specific device can be used with that particular BT1.

To setup a device as the exclusive device, set the BT1 to “Exclusive” mode, clear the pairing list, and then pair the desired exclusive device to the unit. The BT1 makes a note of this device and from that point on, only that exclusive device will be allowed to reconnect to that particular BT1 when in range. As with the reconnect mode, reconnection is done without requiring the front panel button to be pressed by simply selecting that particular BT1 on their smart device.

Once the BT1 has been associated with a device, both the front panel pair button and the remote “pair” command sent via the network are disabled and will have no effect.

In order to attach a different device, either pairing list has to be cleared or the device mode needs to be changed.

*\*Note: In all modes once paired/connected, the Bluetooth® friendly name is able to be detected by other devices. However, while another device may be able to pair and save to its Bluetooth® device list when in this state, breaking the connection of the currently active device will not be possible.*

#### 4.3.3

### - Bluetooth® Audio Bridging

#### 4.3.2.1 - Media Bridging (only)

In this mode (A2DP profile), users may stream audio from media applications on the paired device. The user is protected from errant streaming of call audio over Bluetooth® link.

The media bridging mode is an excellent solution for applications such as hospitality, retail and fitness center background music where users want to maintain call privacy while sharing media audio from their device's media applications.

#### 4.3.2.2 - Call Bridging (only)

In this mode (HFP profile), users may stream incoming/outgoing calls from the paired device to/from the Axon-connected input and output. In this mode, the user is protected from errant streaming of media audio over Bluetooth® link.

The call bridging mode provides call connectivity for conferencing system users' Bluetooth equipped devices to a networked audio based conferencing system. The addition of Bluetooth connectivity provides simple bridging of far end meeting participants for on the fly meeting productivity and backup conferencing connectivity in case of VoIP and Web-based conferencing service failures.

#### 4.3.2.3 - Call & Media Bridging

In this mode, both profiles are available giving users the ability to control access of content (call and media) to the system from the paired device.

*\*Note: If your application requires call privacy, it is recommended to not utilize the combined call and media bridging mode as call audio will be shared automatically over the audio connection.*

### - Bluetooth® Pass-through AVRCP (AV Remote Control Protocol)

Many installed AV systems in both residential and commercial markets feature control products with customizable user interfaces. With a connected Bluetooth audio device as a source, it is desirable to have access to the device information and source content (artist / album / song) for use on the control system UI. Additionally, the end user of the system may control the source from any control panel that has this. This is useful if the device is left somewhere to charge and is out of reach to simply change songs or stop the audio playback.

Control API access is be available for the following AVRCP pass through commands:

- a) Play
- b) Pause
- c) Stop
- d) Next Track
- e) Previous Track
- f) Volume Up
- g) Volume Down
- h) Mute

The AVRCP controls are provided within unIFY Control Panel for system commissioning and testing.



## 5 - AXP20 - Overview



Figure 16 - AXP20 Front Panel

The Axiom AXP20 provides analog audio output breakout, power injection and control system connectivity to Attero Tech's Axiom endpoint products. The installer friendly form factor allows it to be placed on an equipment rack shelf or mounted to any flat surface.

### Features:

- Analog Output - Two balanced line-level analog outputs for connectivity to mixers, amplifiers and signal processors.
- Axiom port - Supports connectivity to any Attero Tech Axiom endpoint.
- RS-232 - Provides RS-232 connectivity to control systems for extending control to supported Axiom products (limited to one control enabled Axiom endpoint on the Axiom bus)
- LED indication of power status

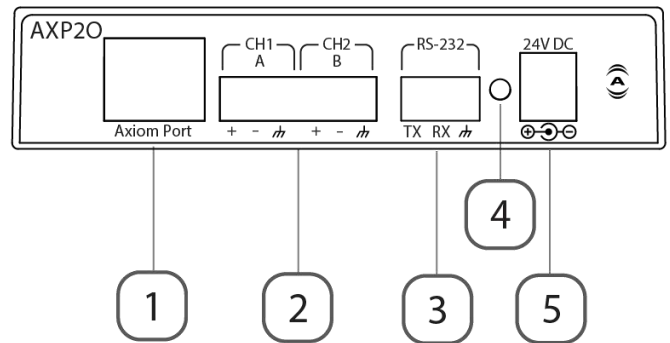

Figure 17 - Product Overview

ID	Description
1	Axiom Port
2	Balanced Audio Output Terminal Blocks
3	RS-232 Terminal Block
4	Power Status LED
5	24V DC Power Input

### 5.1 - AXP20 - What's in the Box

The AXP20 comes supplied with the following:

- Axiom AXP20 device
- 24V AC/DC Power Supply

**- AXP20 - Device Installation**

**- Mounting**

A typical installation will involve mounting an Axiom wall plate into a pre mounted single-gang or larger wall box, standard drywall bracket or mud ring. Before starting, make sure the wall box where the Axiom device is to be installed is pre-wired with a suitable unshielded CAT5/6 cable back to the AXP20 break out box.

5.2

5.3 With the AXP20 powered off, attach the CAT cable from the Axiom port of the AXP20 to the RJ45 on the Axiom device.

Apply power by plugging in the 24V DC power supply to the DC power input on the AXP20. The power LED on the AXP20 should illuminate green. Additionally, the Axiom wall plate should also start up and become ready to operate.

With the cable attached, carefully place the Axiom wall plate into the wall box taking care to not trap the cabling. Once fully in place, secure it with the screws provided. Once the unit is secured in the wall box, fit the Decora plate over the front of the unit and secure it with the screws provided with it. It is recommended to not over-tighten the screws that attach the included Decora wall plate to prevent cracking it.

*\*Note: CAD drawings can be downloaded from the Attero Tech website. Please contact Attero Tech for any further product related information that is not accessible on the website.*

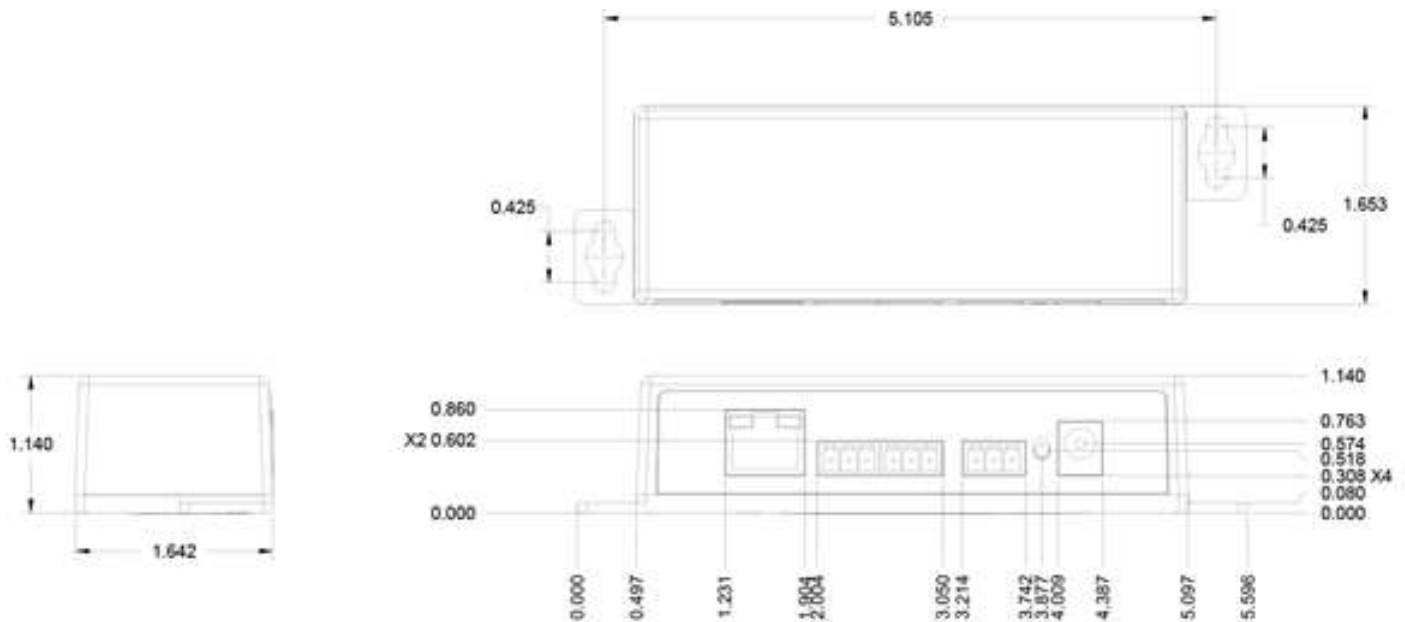

Figure 18 - AXP20 Dimensional Drawings

## - Audio Connections

The AXP20 provides balanced audio outputs to external analog audio equipment. Refer to the following diagrams for connecting the outputs of the AXP20 to audio devices.

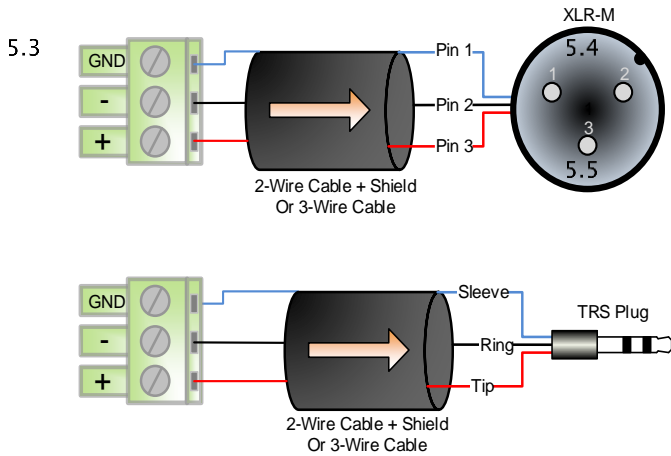

Figure 19 - AXP20 to Balanced Input Wiring Guide

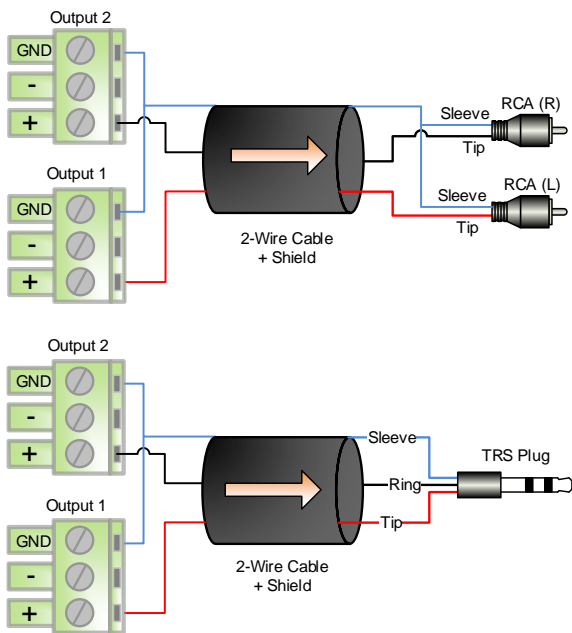

Figure 20 - AXP20 to Unbalanced Input Wiring Guide

## - 3<sup>rd</sup> Party Control

The RS-232 port on the AXP20 break-out box is intended for connectivity to 3<sup>rd</sup> party control systems for extended integration of Axiom into professional AV applications.

## - RS-232 Interface

The RS-232 interface on the AXP20 is a pass through interface to the Axiom port. Actual serial port settings can be found on select Axiom products that support R2-232 control integration features.

## 6- AXPio - Overview



Figure 21 - AXPio Front/Back Panels

The Axiom AXPio provides switchable analog audio input/output breakout, power injection and control system connectivity to Attero Tech's Axiom endpoint products. The installer friendly form factor allows it to be placed on an equipment rack shelf or mounted to any flat surface.

### Features:

- Analog I/O - Two balanced switchable line-level analog inputs/outputs with pad/gain controls for connectivity to mixers, amplifiers and signal processors.
- Axiom port - Supports connectivity to any Attero Tech Axiom endpoint.
- RS-232 - Provides RS-232 connectivity to control systems for extending control to supported Axiom products (limited to one control enabled Axiom endpoint on the Axiom bus)
- LED indication of power status

6.1

### - AXPio - What's in the Box

The AXPio comes supplied with the following:

- Axiom AXPio device
- 24V AC/DC Power Supply

### - USB1 - Device Installation

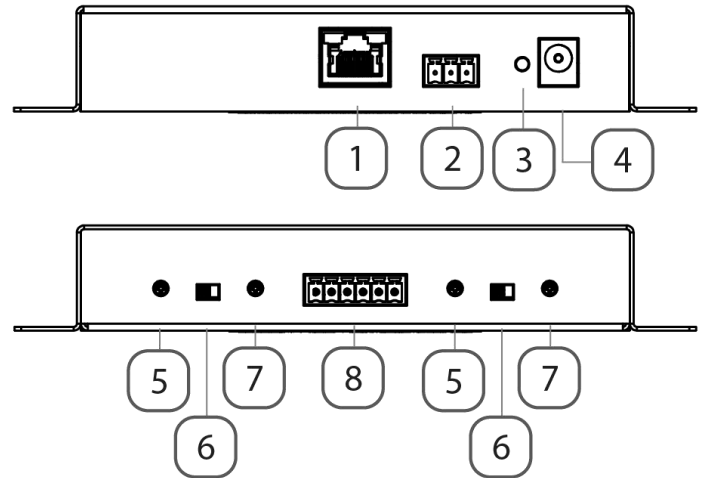

Figure 22 - Product Overview

ID	Description
1	Axiom Port
2	RS232 Terminal Block
3	Power Status LED
4	24V DC Power Input
5	Input Pad Control
6	I/O Mode selection switch
7	Output Gain Control
8	Balanced Audio I/O (based on Mode selection)

## - Mounting

A typical installation will involve mounting an Axiom wall plate into a pre mounted single-gang or larger wall box, standard drywall bracket or mud ring. Before starting, make sure the wall box where the Axiom device is to be installed is pre-wired with a suitable unshielded CAT5/6 cable back to the AXPio break out box.

- With the AXPio powered off, attach the CAT cable from the Axiom port of the AXPio to the RJ45 on the Axiom device.

Apply power by plugging in the 24V DC power supply to the DC power input on the AXPio. The power LED on the AXPio should illuminate green. Additionally, the Axiom wall plate should also start up and become ready to operate.

With the cable attached, carefully place the Axiom wall plate into the wall box taking care to not trap the cabling. Once fully in place, secure it with the screws provided. Once the unit is secured in the wall box, fit the Decora plate over the front of the unit and secure it with the screws provided with it. It is recommended to not over-tighten the screws that attach the included Decora wall plate to prevent cracking it.

*\*Note: CAD drawings can be downloaded from the QSC website. Please contact Attero Tech by QSC for any further product related information that is not accessible on the website.*

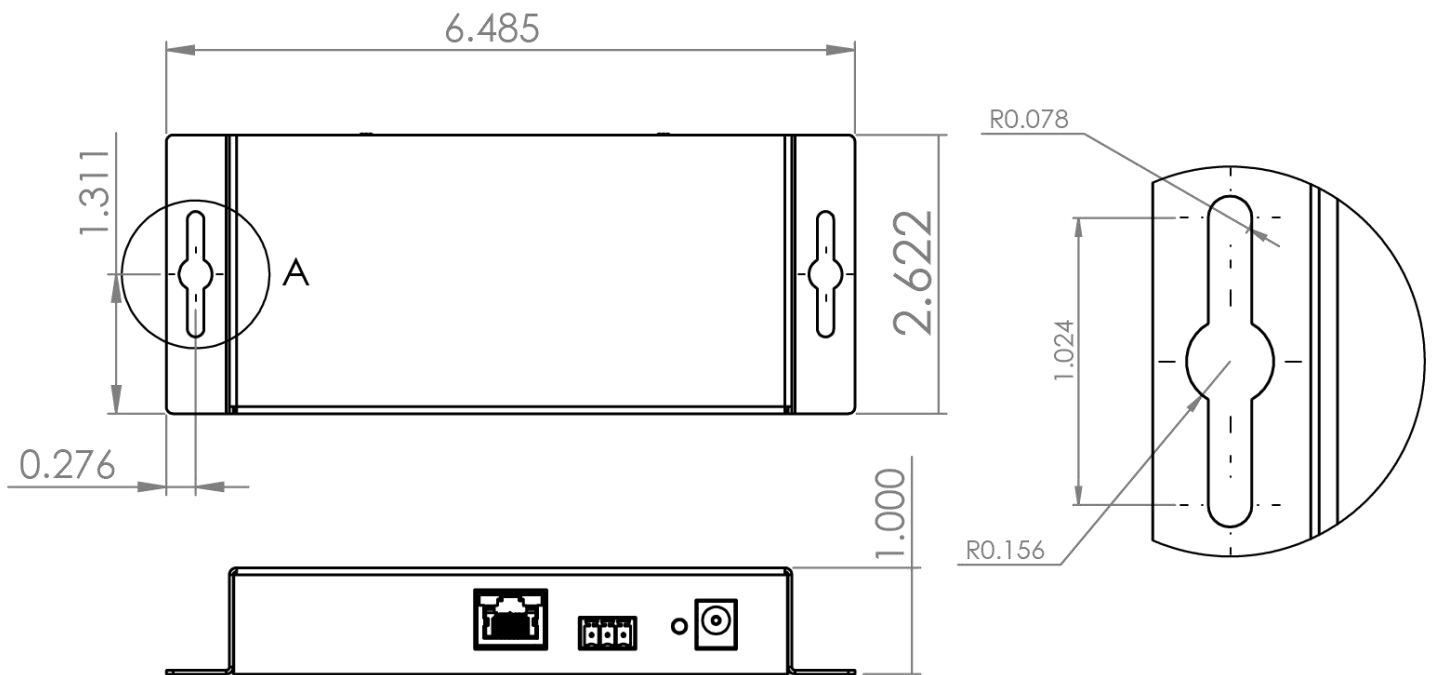

Figure 23 - AXPio Dimensional Drawings

### Hardware Connections

The AXPio provides balanced line-level audio connections to external analog audio equipment. Refer to the following diagrams and instructions for connecting different types of audio devices to the input and/or outputs of the AXPio. Professional grade audio cabling is recommended to achieve the best audio performance throughout the system.

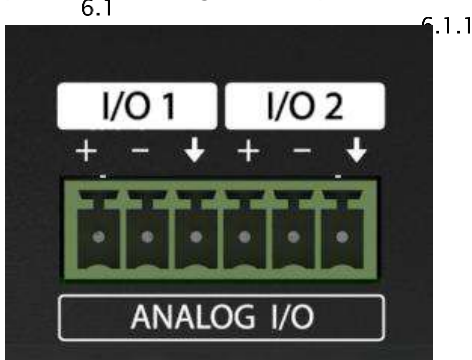

Figure 24 - I/O ports/wiring

#### - Balanced to Balanced Wiring

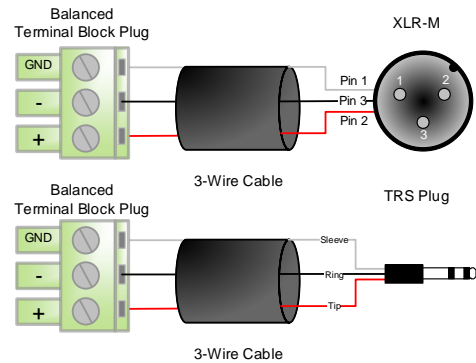

Figure 25 - Balanced Wiring Guide

#### Balanced to Unbalanced Wiring

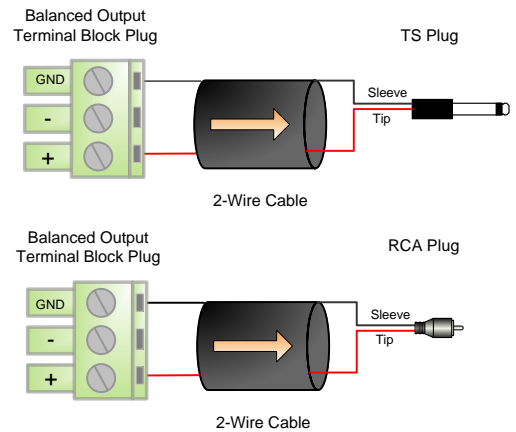

Figure 26 - Unbalanced Wiring Guide

#### - Unbalanced to Balanced Wiring

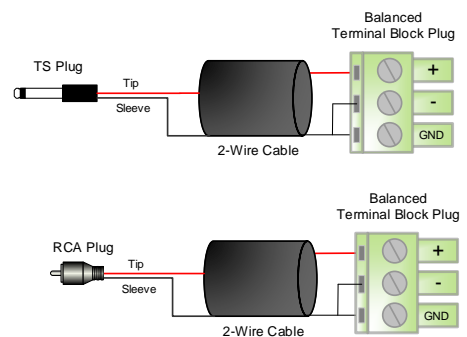

Figure 27 - Unbalanced Wiring Guide

- **Audio Configuration**

Based on the I/O mode selected the device can be configured with two options.



Figure 28 - I/O configuration pots

- **Input Settings**

6.1 The line-level input pads are adjusted using 2 rotary pots. A small screwdriver is needed to adjust the input pad levels. The inputs have an adjustable attenuation range of +24 to 0 dBu, allowing an input full scale input signal range of 0 dBu to +24 dBu.

- **Output Settings**

6.1.2 The output gains are adjusted using 2 rotary pots. A small screwdriver is needed to adjust the gain levels. The outputs have an adjustable gain range of 0 to +24dB, allowing for full scale output levels of 0 dBu to +24 dBu.

- **3<sup>rd</sup> Party Control**

The RS-232 port on the AXPIO break-out box is intended for connectivity to 3<sup>rd</sup> party control systems for extended integration of Axiom into professional AV applications.

- **RS-232 Interface**

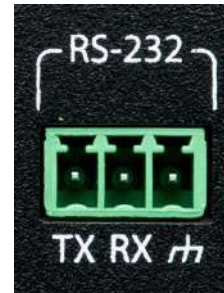

The RS-232 interface on the AXPIO is a pass through interface to the Axiom port. Actual serial port settings can be found on select Axiom products that support R2-232 control integration features.



Attero Tech by QSC **Axiom Product Family**  
User Manual



## ARCHITECTS & ENGINEERS SPECIFICATION

### ML1

The single gang mount interface unit shall have two potentiometers on the front panel for gain control of the 3.5mm input and the balanced input independently.

The unit shall have a 3.5mm stereo consumer level input and a ¼"/XLR combo Mic/Line input. This input is amplified and sent to the Axiom bus. The XLR input shall be dedicated for dynamic microphone signals, while the ¼" input may be used to interface balanced line level audio sources to the Axiom bus.

The unit shall have a selector switches for audio channel routing on the top of the unit.

There shall be two bi-color signal presence and level indicator LEDs on the front of the unit. One for the balanced input and one for the 3.5mm input.

The unit shall have two 8P8C RJ45 type connectors on the back side of the unit.

The unit shall support daisy chain of up to 1 other Axiom device, using 2 RJ45 (8P8C style connectors) for connectivity to CAT-X cabling.

The device shall support mounting the mounting of multiple units side by side in a multi-gang wall box or one unit in a single gang US wall box.

The unit shall be the Attero Tech Axiom ML1.

### USB1

The single gang mount interface unit shall have a USB type-B connector on the front panel for connecting to PC or Mac.

The unit shall have software switchable options for 1x1, 2x0, or 1x0 audio routing. This audio is sent over the Axiom bus.

The unit shall have selector switches for audio channel routing on the top of the unit.

The unit shall have a USB mini type-B connector for software configuration of the unit.

There shall a single bi-color status LED on the front of the unit.

The unit shall have two 8P8C RJ45 type connectors on the back side of the unit.

The unit shall support daisy chain of up to 1 other Axiom device, using 2 RJ45 (8P8C style connectors) for connectivity to CAT-X cabling.

The device shall support mounting the mounting of multiple units side by side in a multi-gang wall box or one unit in a single gang US wall box.

The unit shall be the Attero Tech Axiom USB1.

### BT1

The single gang mount interface unit shall have a 3.5mm stereo consumer level TRRS input/output and a Bluetooth® 3.0 compatible audio receiver/transmitter in a Decora form factor. These inputs/outputs are sent to the Axiom bus.

The unit shall support media and/or call bridging functionality via Bluetooth® connection.

The unit shall have selector switches for audio channel routing on the top of the unit.

The unit shall have a USB mini type-B connector for software configuration of the unit.

There shall be two bi-color signal presence and level indicator LEDs on the front of the unit. One for the balanced input and one for the 3.5mm input.

The unit shall have two 8P8C RJ45 type connectors on the back side of the unit.

The unit shall support daisy chain of up to 1 other Axiom device, using 2 RJ45 (8P8C style connectors) for connectivity to CAT-X cabling.

The device shall support mounting the mounting of multiple units side by side in a multi-gang wall box or one unit in a single gang US wall box.

The unit shall be the Attero Tech Axiom BT1.



## **AXP2O**

The device shall have an 8P8C connector for connectivity to Axiom bus compatible products.

Two 3-position de-pluggable terminal blocks provide balanced analog audio breakout from the Axiom port for connectivity to the balanced or unbalanced inputs of external audio equipment.

A single, 3-position de-pluggable terminal block provides RS-232 pass through connectivity to the Axiom port

The 24VDC input provides power injection to the Axiom port/bus.

The interface shall be compliant with the RoHS directive.

The device shall be the Attero Tech Axiom AXP2O.

## **AXPio**

The flange mount interface unit shall two installer selectable analog inputs or outputs. The line-level analog inputs shall have an attenuation range of +24 to 0 dBu, allowing an input full scale input signal range of 0 dBu to +24 dBu. The line-level analog outputs shall have a gain range of 0 to +24dB, allowing for full scale output levels of 0 dBu to +24 dBu.

The device shall have an 8P8C connector for connectivity to Axiom bus compatible products.

Two 3-position de-pluggable terminal blocks provide balanced analog audio breakout from the Axiom port for connectivity to the balanced or unbalanced inputs or outputs of external audio equipment.

A single, 3-position de-pluggable terminal block provides RS-232 pass through connectivity to the Axiom port

The 24VDC input provides power injection to the Axiom port/bus.

The interface shall be compliant with the RoHS directive.

The device shall be the Attero Tech Axiom AXPio.

## Device Specifications

### ML1 Specs

Audio Inputs (Mic/Line)	
Connector Type	XLR - ¼" Combo
Gain	0 to 50 dB
Input Impedance	>2kOhms at any gain (mic) >10kOhms Line
Maximum Input Levels	+20 dBu @ minimum gain (XLR) +18 dBu @ minimum gain (1/4")
THD+N	<0.05% @ 1 kHz, -3 dBFS input, 20-20kHz
Frequency Response	20-20 kHz, +/- 1 dB (1/4"), 50-20kHz +/- 1 dB (XLR)
Dynamic Range	>110 dB at minimum gain
EIN	-115 dBu
Audio Inputs (3.5 mm Line)	
Connector Type	3.5mm TRS
Gain	0 to 20 dB
Input Impedance	>10K ohms at any gain
Maximum Input Levels	+12 dBu @ minimum gain
THD+N	<0.05% @ 1 kHz, -3 dBFS input. 20-20kHz
Frequency Response	20-20 kHz, +/- 1 dB
Dynamic Range	>110 dB at minimum gain

Axiom	
Physical Layer	Analog Audio, RS-232 Control, 24V DC Power
Connector (s)	8P8C
Cable Quality	CAT-5e or better, UTP
Power Specifications	
DC Power	24V DC (via Axiom port)
Power Consumption	50mA @ 24V / 1.2W
Physical Dimensions	
Width	1.66"
Height	1.14"
Depth	2.35"
Weight	0.35 lbs.
Regulatory Compliance	
Certifications	WEEE RoHS REACH
Environmental Operating Specifications	
Operating Temperature	0 to 40° C

### USB1 Specs

USB	
Connector Type	USB Type B USB Mini Type B (for configuration)
Audio Connectivity	USB Audio 1.1, Compatible with Windows 7 or newer, and MacOS 10.7 or newer
Input Impedance	>2kOhms at any gain (mic) >10kOhms Line
Maximum Input Levels	+20 dBu @ minimum gain (XLR) +18 dBu @ minimum gain (1/4")
THD+N	<0.05% @ 1 kHz, -3 dBFS input, 20-20kHz
Frequency Response	20-20 kHz, +/- 1 dB (1/4"), 50-20kHz +/- 1 dB (XLR)
Dynamic Range	>110 dB at minimum gain
Audio Output (3.5 mm Line)	
Connector Type	3.5mm TRS
Gain	0 to 20 dB
Input Impedance	>10K ohms at any gain
Maximum Input Levels	+12 dBu @ minimum gain
THD+N	<0.05% @ 1 kHz, -3 dBFS input. 20-20kHz
Frequency Response	20-20 kHz, +/- 1 dB
Dynamic Range	>110 dB at minimum gain

Axiom	
Physical Layer	Analog Audio, RS-232 Control, 24V DC Power
Connector (s)	8P8C
Cable Quality	CAT-5e or better, UTP
Power Specifications	
DC Power	24V DC (via Axiom port)
Power Consumption	50mA @ 24V / 1.2W
Physical Dimensions	
Width	1.66"
Height	1.14"
Depth	2.35"
Weight	
Regulatory Compliance	
Certifications	WEEE RoHS REACH
Environmental Operating Specifications	
Operating Temperature	0 to 40° C

## BT1 Specs

Audio Inputs (Bluetooth/Line)	
Input Types	Stereo Bluetooth® v3.0 audio receiver Stereo Unbalanced Inputs on 3.5mm TRRS
Bluetooth Range	10m (30ft) minimum
Input Impedance	>10k Ohms Line (3.5mm)
Maximum Input Levels	+20 dBu @ minimum gain (XLR) +18 dBu @ minimum gain (1/4")
THD+N	<0.05% @ 1 kHz, -3 dBFS input, 20-20kHz
Frequency Response	20-20 kHz, +/- 1 dB (1/4"), 50-20kHz +/- 1 dB (XLR)
Dynamic Range	90 dB at minimum gain
Audio Outputs (Bluetooth/Line)	
Output Types	Stereo Bluetooth® v3.0 audio transmitter Mono line level on 3.5mm TRRS
Output Impedance	<200 ohms on 3.5mm
Frequency Response	20-20 kHz, +/- 1 dB
Bluetooth® Profiles	
A2DP	Media Audio Bridging (100-150ms latency)
HFP	Hands-Free Call Bridging (30ms latency)
AVRCP	A/V Remote Control

Axiom	
Physical Layer	Analog Audio, RS-232 Control, 24V DC Power
Connector (s)	8P8C
Cable Quality	CAT-5e or better, UTP
Power Specifications	
DC Power	24V DC (center positive barrel jack)
Power Consumption	50mA @ 24V / 1.2W
Physical Dimensions	
Width	1.66"
Height	1.14"
Depth	2.35"
Weight	
Regulatory Compliance	
Certifications	WEEE RoHS REACH
Environmental Operating Specifications	
Operating Temperature	0 to 40° C

## AXP20 Specs

Audio Outputs	
Connector Type	3.81 mm, 3 position de-pluggable terminal blocks
Input Impedance	>2kOhms at any gain (mic) >10kOhms Line
Maximum Output Levels	+20 dBu
THD+N	<0.05% @ 1 kHz, -3 dBFS input, 20-20kHz
Frequency Response	20-20 kHz, +/- 1 dB
Dynamic Range	>100 dB
Control Port	
Connector Type	3.81 mm, 3 position de-pluggable terminal blocks
Physical Layer	RS-232

Axiom Port	
Physical Layer	Analog Audio, RS-232 Control, 24V DC Power
Connector (s)	8P8C
Cable Quality	CAT-5e or better, UTP
Power Specifications	
DC Power	24V DC (center positive barrel jack)
Power Consumption	<30mA @ 24V / 0.72 W
Physical Dimensions	
Width	5.6"
Height	4.2"
Depth	1.66"
Weight	0.15 lbs.
Regulatory Compliance	
Certifications	WEEE RoHS REACH
Environmental Operating Specifications	
Operating Temperature	0 to 40° C



## AXPio Specs

Audio Inputs (when selected)	
I/O Type	Two switchable Balanced and RF filtered 3-pin de-pluggable terminal blocks
Maximum Input Levels	+24 dBu to 0dBu line-level
THD+N	<= 0.05% at 3dB for all attenuation levels
Dynamic Range	>= 100 dB (20 -22 kHz)
Frequency Response	20 to 20 kHz, +/- 1 dB at all attenuation settings
Audio Outputs (when selected)	
I/O Type	Two switchable Balanced and RF filtered
Maximum output level	0 dBu to +24 dBu (0 to +24 dB gain range)
THD+N	<= 0.05% at 3dB for all gain levels
Dynamic Range	>= 95 dB (20 -22 kHz) @ any output gain

Axiom Port	
Physical Layer	Analog Audio, RS-232 Control, 24V DC Power
Connector (s)	8P8C
Cable Quality	CAT-5e or better, UTP
Power Specifications	
DC Power	24V DC (center positive barrel jack)
Power Consumption	<30mA @ 24V / 0.72 W
Physical Dimensions	
Width	6.485"
Height	1"
Depth	2.622"
Weight	
Regulatory Compliance	
Certifications	WEEE RoHS REACH
Environmental Operating Specifications	
Operating Temperature	0 to 40° C