

BOSE[®]

B2

Bass Module

Owner's Guide

Guía de usuario

Notice d'utilisation

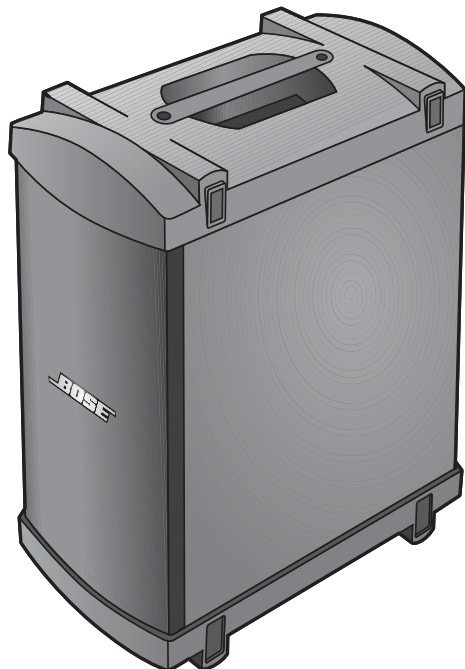

B2 BASS MODULE

Introduction

Thank you for purchasing the Bose® B2 bass module for your L1® model 1S or model II system. The L1 power stand bass module output can adequately drive one B2 bass module. A second B2 bass module can be added (to your L1 model II system only) by using a Model A1 PackLite power amplifier connected to the bass line output of the power stand.

Carefully unpack the carton and check for the items shown in Figure 1. Save all packing materials, which provide the safest way to transport your system. If an item appears to be damaged, do not attempt to use it. Notify Bose or your authorized Bose dealer immediately.

Figure 1

Carton contents

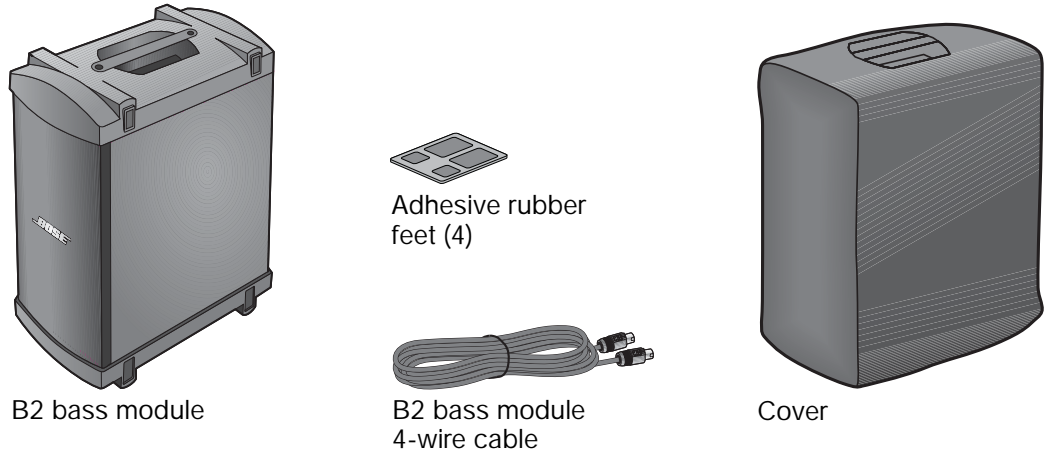

For importantly safety information and more information on using the B2 module, please refer to the owner's guide that came with your L1 system, or visit www.Bose.com/livesound.

Positioning the B2 bass module

The B2 bass module can be placed vertically or horizontally on the floor next to the power stand. When placed horizontally, you can build a stack of up to two modules (Figure 2).

Figure 2

B2 placement options

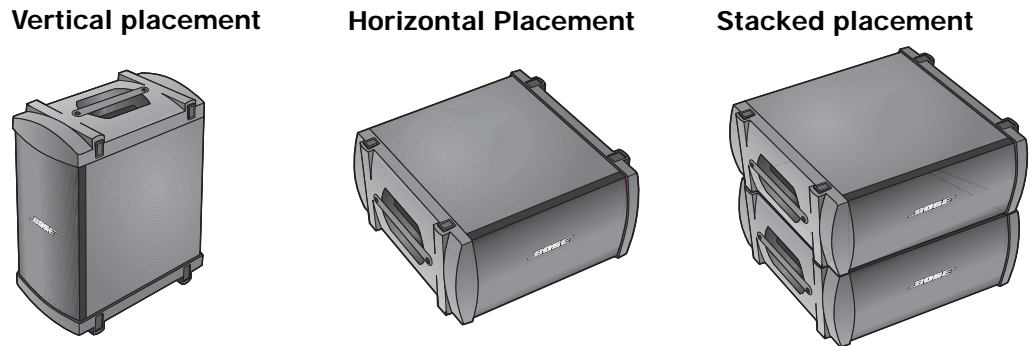

Do not stack more than two B2 bass modules.

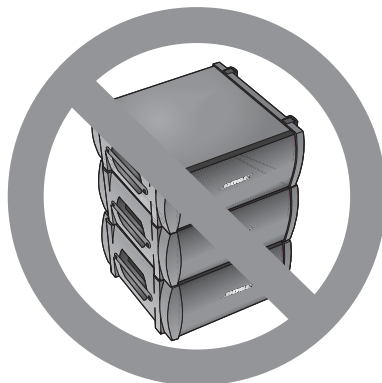

Connecting one B2 bass module

1. Plug one end of the B2 bass module cable into the B2 connector (Figure 3). Rotate the plug clockwise to lock it in place. Listen for a soft click to ensure the connector is locked.
2. Plug the other end of the cable into the **Bass Module Out** connector on the power stand. Rotate the plug clockwise to lock it.

Note: To disconnect a B2 cable, slide back the metal tab on the body of the plug, rotate the plug counterclockwise and pull it out of the connector.

Figure 3

Bass module connections

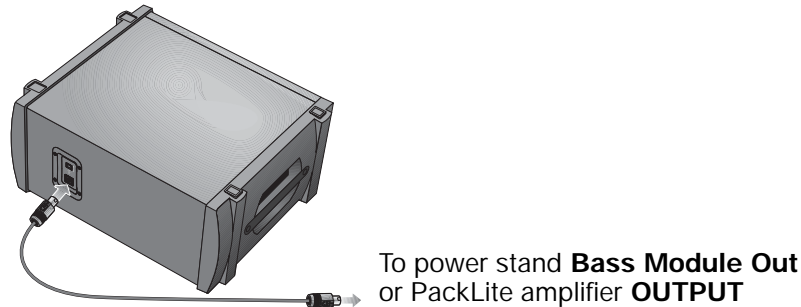

CAUTIONS:

- DO NOT connect any bass module other than the B2 or the B1 to the power stand.
- Use only the supplied B2 bass module 4-wire cable to connect the B2 bass module to the power stand. The power stand uses the signals on two of the wires to automatically sense the state of the B2 bass module. DO NOT substitute the supplied cable with a 2-wire speaker cable.

Connecting a second B2 bass module (L1® model II system only)

Using a PackLite power amplifier model A1 allows you to add one additional B2 module to your L1 model II system. Refer to the A1 Owner's Guide for detailed operating instructions.

1. Make sure the A1 amplifier power switch is OFF.
2. Plug one end of the supplied ¼" TRS cable into the Bass-Line Out connector on the power stand. Plug the other end into the INPUT connector on the A1 amplifier.
3. Connect a B2 bass module cable from the OUTPUT connector on the A1 to a B2 bass module.
4. Plug one end of the AC power cord into the A1 amplifier and plug the other end into an AC (mains) outlet.
5. Switch the A1 power switch to ON (I).

Figure 4

Connections for two bass modules

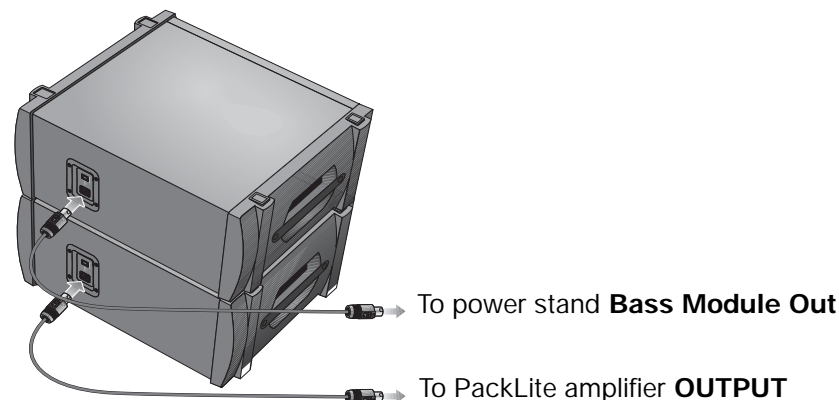

B2 Rear Panel

The B2 bass module includes a switch allowing you to select the appropriate level of bass output for your application.

There are three settings:

- +** = Bass voicing designed for DJ/Music playback applications
- Normal** = Bass voicing ideal for bass guitar or live sound application when mic'ing a kick drum
- = Bass voicing which is perfect for acoustic guitar and vocal

Figure 5

Bass Level switch

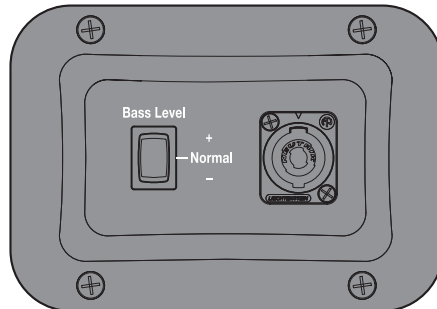

Attention L1 Model II users: In order to take advantage of the B2 rear panel bass level features you must upgrade your power stand firmware to version 1.4 or higher. If your power stand firmware is not current, the rear panel switch must be in the Normal position. + or - switch positions will not work. For the latest firmware please visit www.Bose.com/livesound.

Attention L1 model I and Classic users: When using the B2 with the L1 model I or Classic systems the rear panel switch must be in the **Normal** position. + or - switch positions will not work.

Attaching rubber feet

On smooth surfaces like wood floors, certain frequencies may cause the loudspeaker to slide. For added stability and protection, detach the included self-adhesive rubber feet and attach them to the loudspeaker in the four recesses (as shown in Figure 6). When using the loudspeaker, keep the rubber feet in contact with the floor.

Figure 6

Attaching rubber feet

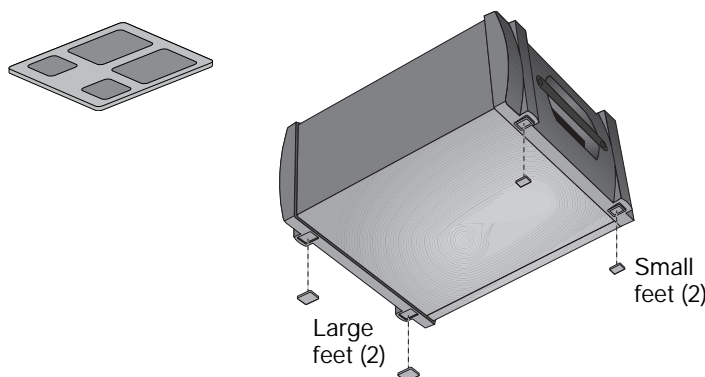

Technical Information

Dimensions: 23.4"H x 13.31"W x 18.9"D (59.4 cm x 33.8 cm x 48 cm)

Weight: 45 lb (20.41 kg)

Impedance: 4 ohms



This product conforms to all applicable EU directive requirements. The complete declaration of conformity can be found at www.Bose.com/compliance.

PackLite is a registered trademark of Bose Corporation in the U.S. and/or other countries.



356142-0010

BOSE[®]
Better sound through research[®]

©2012 Bose Corporation, The Mountain
Framingham, MA 01701-9168 USA
AM365142 Rev.00
www.Bose.com/livesound