

# MW732 Digital Projector

## MW732 Features

- 2Feature High Light
- 4000 ANSI Lumen High Brightness
- 20000:1 High Contrast Ratio
- Up to 15000 hrs long lamp life
- USB Reader Compatible
- Networking Connectively



## Features

1. HDMI-1
2. HDMI-2/MHL
3. PC (D-sub 15pin)
4. Monitor out (D-sub 15pin,Female)
5. Audio in(mini jack)
6. Audio out (mini jack)
7. LAN Port(RJ45 for Network)
8. RS232 In (D-sub 9pin, male)
9. USB TypeA (for USB reader)
10. USB TypeA (for Wireless Dongle)
11. USB (Type mini B)
12. IR Receiver(Front+Top)



## Ceiling Mount Chart

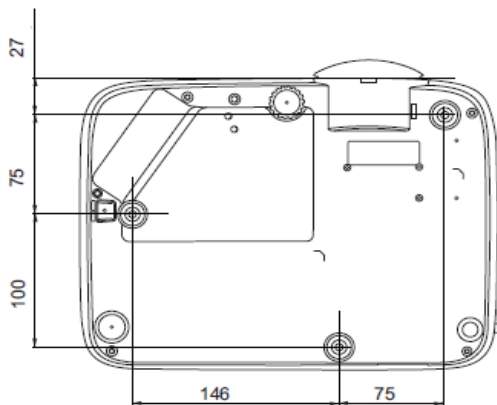

Ceiling mount screw: M4 x 8  
(Max L = 25 mm; L = 20 mm)

## Dimensions

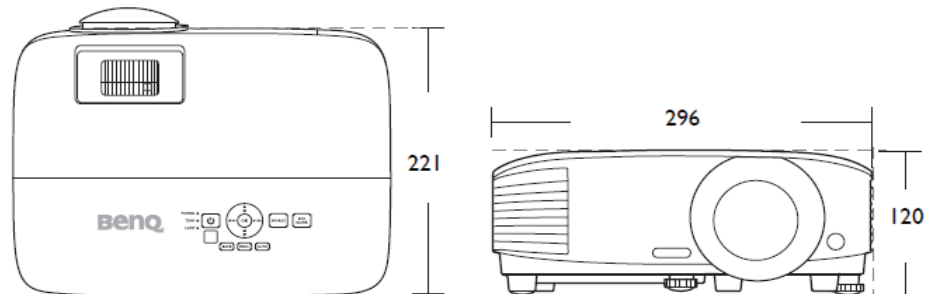

296 mm (W) x 120 mm (H) x 221 mm (D)

| SPECIFICATIONS              |                                   | MW732   |
|-----------------------------|-----------------------------------|---|
| <b>DISPLAY</b>              | Projection System                 | DLP Single 0.65" WXGA   |
|                             | DMD type                          | DC3 DMD chip  |
|                             | Native Resolution                 | 1280 x 800 pixels, 16:10  |
|                             | Brightness                        | 4,000 Lumens  |
|                             | Contrast Ratio*                   | 20,000:1  |
|                             | Display Color                     | 1.07 Billion Colors   |
|                             | Aspect Ratio                      | Native 16:10 (5 aspect ratio selectable) †  |
|                             | Light Source                      | Lamp (240W)   |
|                             | Light Source life*                | 4000/8000/8000/15000hrs (Normal/Eco/SmartEco/Lampsave Mode) †   |
| <b>OPTICAL</b>              | Throw Ratio                       | 1.21~1.57   |
|                             | Zoom Ratio                        | 1.3X  |
|                             | Lens Control                      | Manual Zoom and Focus   |
|                             | Lens shift                        | N/A   |
|                             | Keystone Correction               | 2D keystone, Vertical ± 30 & Horizontal ± 20 degrees, Auto Vertical keystone  |
|                             | Projection Offset                 | 110%±2.5% (Full-Height)   |
|                             | Projection Size                   | 30"~300" †  |
| <b>AUDIO</b>                | Built-in Speaker                  | 10W x1  |
| <b>SPECIAL FEATURE</b>      | Security                          | Kensington Lock, Security Bar   |
|                             | Feature                           | 2D Keystone, Auto Vertical keystone, Corner Fit, USB Reader, LAN Control, AMX/ PJ Link/Crestron/Extron IPL Compatible. MDA Compatibility LAN Display, Optional Wireless Display, Split Screen, Support Meeting/Classroom collaboration via QCast Software. (Conference Control)                             |
| <b>COMPATIBILITY</b>        | Resolution Support                | VGA(640 x 480) to WUXGA_RB(1920 x 1200)   |
|                             | Horizontal Frequency              | 15~102KHz   |
|                             | Vertical Scan Rate                | 23 ~ 120 Hz   |
|                             | HDTV Compatibility                | 480i, 480p, 576i, 567p, 720p, 1080i, 1080p  |
|                             | Video Compatibility               | NTSC, PAL, SECAM*   |
| <b>POWER</b>                | Power Consumption(Max/Normal/Eco) | Max 355W. Normal 320W. Eco 240W.  |
|                             | Standby Power Consumption         | Normal < 0.5Watts. Network < 2W.  |
|                             | Power Supply                      | 100 ~ 240V AC   |
| <b>DIMENSION AND WEIGHT</b> | Product Dimensions (WxHxD)        | 296x 120 x 221 mm   |
|                             | Product Weight                    | 2.5kg   |
| <b>OPERATION CONDITION</b>  | Noise Level(Normal/Eco)           | 33/29 dBA   |
|                             | Operating Temperature             | 0 ~ 40oC  |
| <b>OSD</b>                  | On-Screen Display Languages       | Arabic/Bulgarian/ Croatian/ Czech/ Danish/ Dutch/ English/ Finnish/ French/ German/ Greek/ Hindi/ Hungarian/ Italian/ Indonesian/Japanese/ Korean/ Norwegian/ Polish/ Portuguese/ Romanian/ Russian/ Simplified Chinese/ Spanish/ Swedish/ Turkish/Thai/TraditionalChinese/Vietnamese /Farsi (30 Languages) |
| <b>ACCESSORIES</b>          | <b>Standard</b>                   | <b>Optional</b>   |
|                             | Power Cord (by region)            | Spare Lamp Kit ( P/N:5J.JGS05.001)  |
|                             | Remote Control (RCE013)           | 3D Glasses (5J.J9H25.002)   |
|                             | AAA Batteryx2                     | Wireless Dongle: WDRT8192 USB Dongle( 5J.J3F28.X01)   |
|                             | VGA cable                         | Wireless Dongle: QCast Mirror (5A.JH328.10X)  |
|                             | Warranty Card (by region)         | Wireless Dongle: QCast (5J.JCK28.X01)   |
|                             | QSG (4J.JGR01.001)                | Ceiling mount   |
|                             | User Manual CD (5B.JGR01.001)     |   |
| Lens Cover                  |                                   |   |

\*The Contrast is measure by Full On Full Off standard.

\* LightSource life results will vary depending on environmental conditions and usage. Actual product's features and specifications are subject to change without notice.

\* Storage: Temperature: -20~60°C; Humidity: 10~90%RH (without condensation)



**BenQ America Corp.**  
www.BenQ.us

BenQ is a registered trademark of BenQ Corp. All rights reserved. Product names, logos, brands, and other trademarks featured or referred to in this material are the property of their respective trademark holders. Specifications subject to change without notice.

