

## Features of the WL2082-i

- Installation-optimized design brings affordable and uncompromised line array performance to a broader range of venues
- Compact and attractive appearance, available in black and white, harmonizes with any installation environment
- Wide 140° horizontal coverage
- Economical and easy-to-install suspension system with ample array adjustability

## Features of the WL118-sw

- Single 18" subwoofer in a bass-reflex enclosure
- 850 watt continuous power capacity
- Frequency range down to 29 Hz
- May be suspended at the top, or behind the WL2082-i array
- Available in black or white to harmonize with venue décor



ILA is a line array system designed specifically for installation in a variety of venues including houses of worship, sports facilities, clubs and other entertainment venues. ILA System v2 is a complete system consisting of line array, subwoofer, processing, amplification and suspension accessories. The result is an accessible system with very high performance, moderate cost and ease of deployment.

Most line array systems currently available are designed for touring applications, which require extreme ruggedization and expensive suspension hardware. As a result, overall system cost is driven beyond the means of many facilities that could benefit from line array performance. By focusing on installation applications, using a molded enclosure and simplifying the rigging design, QSC has driven cost out of the ILA System while retaining the sound quality, coverage and power of high end touring line array systems.

### WL2082-i

Each Installation Line Array element uses a pair of high-power, neodymium magnet, 8" diameter low-frequency drivers. Both woofers produce low frequencies but only one covers the mid-range resulting in more uniform directivity in the crossover region. For high

frequencies, a pair of 1.75" (voice coil diameter) neodymium compression drivers with titanium domes are mounted on a multiple aperture diffraction waveguide\* that provides extremely wide coverage (140°). As a result, a WL2082-i system will rarely require additional side or center fill speakers and solid stereo imaging is preserved across the listening area.

The system may be used in bi-amplified or tri-amplified mode. In general, the tri-amplified mode will produce the best performance and, for arrays larger than four boxes, will not increase the total cost of system amplification.

Available in black or white, the WL2082-i enclosure is made of high impact polystyrene with extensive internal ribs to eliminate acoustic losses due to sidewall flex. The Installation Line Array may be used in outdoor applications where the system is not directly exposed to the elements. The enclosure material is formulated with UV inhibitors, the grille is made of aluminum and the woofer cones are weather resistant.

### Rigging

Rigging for the ILA is simple, flexible and safe providing a 10:1 design factor with twelve WL2082-i systems in the array (see the owner's

manual for details before planning any array suspension). The array is assembled with the included bolts and the relative angle between adjacent boxes is adjustable in 1° increments for precise tailoring of vertical coverage. For those who prefer quick release pins to the included bolts, an optional kit of four quick release pins (QRP-KIT-1) is available.

### Subwoofer

The subwoofer for ILA System v2 is the WL118-sw, a single 18" version of the popular WideLine-10 touring, dual 18" subwoofer and offers an impressive combination of punch and low-frequency extension. ILA subs may be suspended at the top of an ILA array using the standard FP2082-i array frame. When trim height is limited, the ILA sub may be suspended behind the array using the available EB2082-i extension bar.

\*U.S. Patent No. 7,177,437

# ILA System v2

## Intrinsic Correction™

Modern line arrays rely on digital signal processing to perform their best. QSC has developed a sophisticated approach to creating system tunings that improve performance and dramatically simplify system set-up. Intrinsic Correction is far more than just signal processing. It is also a process that begins by taking extensive laboratory measurements (typically 60-75) of the loudspeaker and then spatially averaging those measurements. Once the spatially averaged response of the loudspeaker is determined, a combination of IIR and FIR filters is applied to adjust the time, frequency and amplitude response to a maximally flat band-pass target.

The result is that signal processing adjustment is no longer a task requiring complicated test gear, prolonged measurements and golden-eared experts. The QSC SC28 System Controller offers preset recall simplicity. Just input the size of the array, the included coverage angle and the amplifier model numbers. The SC28 does all the needed calculations. While it's simple to use, the SC28 offers audio quality so good it's being used on major concert tours.

For applications requiring networked audio and more complex signal routing, BASIS™ processors also support ILA.



SC28

## Array Configurations

The following table provides information regarding the maximum number of WL2082-i line array elements and WL118-sw subwoofers that may be suspended using various configurations of the available suspension accessories. The calculations for this table are based on a 10:1 design factor. See owner's manual for detail before designing or suspending an array. While a single WL2082-i may be used for some specialized applications such as stage lip front fill, or under balcony fill, three or more ILA elements are required before the system begins to perform as a true line array.

| Configuration  | Maximum WL2082-i in array | Maximum WL118-sw in array |
|--|---------------------------|---------------------------|
| Single FB2082-i  | 12                        | 0                         |
|  | 8                         | 2                         |
|  | 5                         | 3                         |
|  | 0                         | 4                         |
| Dual FB2082-i with EB2082-i (subwoofers behind line array) | 12                        | 3                         |
|  | 10                        | 4                         |



## Aiming the ILA System v2

Aiming and array configuration of an ILA System is supported by EASE Focus, a two-dimensional acoustic simulation application that calculates vertical coverage of a venue by a line array system. This free software may be downloaded from the support section of the QSC website at [qscaudio.com](http://qscaudio.com).

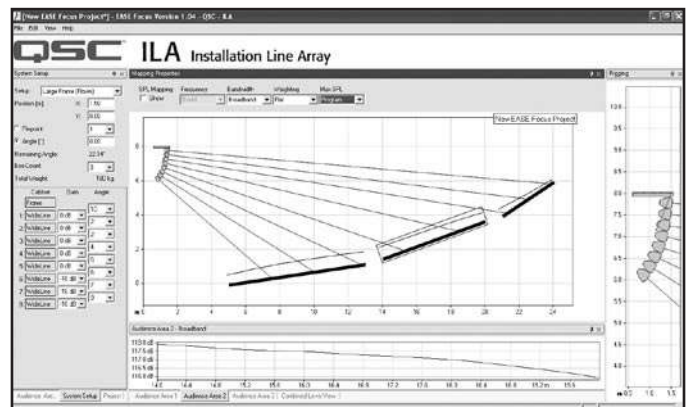

Specifications subject to change without notice.

## Specifications

|   | <b>WL2082-i</b>   | <b>WL118-sw</b>   |           |         |       |    |    |       |    |     |       |    |     |       |    |    |  |            |  |            |  |       |     |       |     |       |           |       |           |       |           |  |  |       |           |  |  |
|---|---|---|-----------|---------|-------|----|----|-------|----|-----|-------|----|-----|-------|----|----|--|------------|--|------------|--|-------|-----|-------|-----|-------|-----------|-------|-----------|-------|-----------|--|--|-------|-----------|--|--|
| Configuration   | 3-way, bi-amp or tri-amp mode   | Vented box  |           |         |       |    |    |       |    |     |       |    |     |       |    |    |  |            |  |            |  |       |     |       |     |       |           |       |           |       |           |  |  |       |           |  |  |
| Transducers   |   |   |           |         |       |    |    |       |    |     |       |    |     |       |    |    |  |            |  |            |  |       |     |       |     |       |           |       |           |       |           |  |  |       |           |  |  |
| High-frequency  | Dual 50 W, 8Ω 1" exit, 1.75" titanium diaphragm, neodymium magnet assembly  | –   |           |         |       |    |    |       |    |     |       |    |     |       |    |    |  |            |  |            |  |       |     |       |     |       |           |       |           |       |           |  |  |       |           |  |  |
| Low-frequency   | Dual 200 W, 16Ω 8" woofer, 2" voice coil, neodymium magnet assembly, weather resistant cone   | 850 W, 8Ω 18" woofer with a 4" voice coil, ceramic magnet assembly  |           |         |       |    |    |       |    |     |       |    |     |       |    |    |  |            |  |            |  |       |     |       |     |       |           |       |           |       |           |  |  |       |           |  |  |
| Frequency Response (±3 dB)                                | 80 Hz – 20 kHz  | 32 Hz – 200 Hz  |           |         |       |    |    |       |    |     |       |    |     |       |    |    |  |            |  |            |  |       |     |       |     |       |           |       |           |       |           |  |  |       |           |  |  |
| Frequency Range (-10 dB)                                  | 68 Hz – 22 kHz  | 29 Hz – 800 Hz  |           |         |       |    |    |       |    |     |       |    |     |       |    |    |  |            |  |            |  |       |     |       |     |       |           |       |           |       |           |  |  |       |           |  |  |
| Nominal Impedance   | HF: 16Ω<br>LF bi-amp mode: 8Ω<br>LF tri-amp mode: 16Ω (x 2)   | –<br>–<br>LF: 8Ω  |           |         |       |    |    |       |    |     |       |    |     |       |    |    |  |            |  |            |  |       |     |       |     |       |           |       |           |       |           |  |  |       |           |  |  |
| Continuous Power Capacity <sup>1</sup> /Recommended Power | HF: 100 W/200 W<br>LF bi-amp mode: 400 W/800 W<br>LF tri-amp mode: 200 W/400 W (x 2)  | –<br>–<br>LF: 850 W/1750 W  |           |         |       |    |    |       |    |     |       |    |     |       |    |    |  |            |  |            |  |       |     |       |     |       |           |       |           |       |           |  |  |       |           |  |  |
| Sensitivity (1 W at 1 m)                                  | HF: 106 dB<br>LF: 96 dB   | –<br>LF: 98 dB  |           |         |       |    |    |       |    |     |       |    |     |       |    |    |  |            |  |            |  |       |     |       |     |       |           |       |           |       |           |  |  |       |           |  |  |
| Maximum Output Continuous/Peak (SPL at 1 m)               | HF: 126 dB/132 dB<br>LF: 122 dB/128 dB  | –<br>LF: 128.5 dB/134.5 dB  |           |         |       |    |    |       |    |     |       |    |     |       |    |    |  |            |  |            |  |       |     |       |     |       |           |       |           |       |           |  |  |       |           |  |  |
| Nominal Coverage  | H: 140°<br>V: dependent on number of elements used  | –<br>–  |           |         |       |    |    |       |    |     |       |    |     |       |    |    |  |            |  |            |  |       |     |       |     |       |           |       |           |       |           |  |  |       |           |  |  |
| Cabinet Type  | Ported, elliptical/trapezoidal  | Vented subwoofer  |           |         |       |    |    |       |    |     |       |    |     |       |    |    |  |            |  |            |  |       |     |       |     |       |           |       |           |       |           |  |  |       |           |  |  |
| Enclosure Material  | HIPS (high impact polystyrene) with UV protectant   | 18 mm Baltic birch plywood  |           |         |       |    |    |       |    |     |       |    |     |       |    |    |  |            |  |            |  |       |     |       |     |       |           |       |           |       |           |  |  |       |           |  |  |
| Finish  | Available in black (WL2082-i BLK) or white (WL2082-i WHT) paintable   | Available in black (WL118-sw BLK) or white (WL118-sw WHT) paintable |           |         |       |    |    |       |    |     |       |    |     |       |    |    |  |            |  |            |  |       |     |       |     |       |           |       |           |       |           |  |  |       |           |  |  |
| Grille  | Perforated, formed aluminum   | 16 gauge powder-coated steel with cloth backing                     |           |         |       |    |    |       |    |     |       |    |     |       |    |    |  |            |  |            |  |       |     |       |     |       |           |       |           |       |           |  |  |       |           |  |  |
| Connectors  | 2 x NL8 in parallel   | 2 x NL8 in parallel/2 x NL4 in parallel                             |           |         |       |    |    |       |    |     |       |    |     |       |    |    |  |            |  |            |  |       |     |       |     |       |           |       |           |       |           |  |  |       |           |  |  |
| Pin Outs  | <table border="1"> <thead> <tr> <th>Pins</th> <th>Bi-Amp</th> <th>Tri-Amp</th> </tr> </thead> <tbody> <tr> <td>1+/1-</td> <td>NC</td> <td>NC</td> </tr> <tr> <td>2+/2-</td> <td>NC</td> <td>LF2</td> </tr> <tr> <td>3+/3-</td> <td>LF</td> <td>LF1</td> </tr> <tr> <td>4+/4-</td> <td>HF</td> <td>HF</td> </tr> </tbody> </table>   | Pins  | Bi-Amp    | Tri-Amp | 1+/1- | NC | NC | 2+/2- | NC | LF2 | 3+/3- | LF | LF1 | 4+/4- | HF | HF | <table border="1"> <thead> <tr> <th>Pins (NL8)</th> <th></th> <th>Pins (NL4)</th> <th></th> </tr> </thead> <tbody> <tr> <td>1+/1-</td> <td>Sub</td> <td>1+/1-</td> <td>Sub</td> </tr> <tr> <td>2+/2-</td> <td>Pass thru</td> <td>2+/2-</td> <td>Pass thru</td> </tr> <tr> <td>3+/3-</td> <td>Pass thru</td> <td></td> <td></td> </tr> <tr> <td>4+/4-</td> <td>Pass thru</td> <td></td> <td></td> </tr> </tbody> </table> | Pins (NL8) |  | Pins (NL4) |  | 1+/1- | Sub | 1+/1- | Sub | 2+/2- | Pass thru | 2+/2- | Pass thru | 3+/3- | Pass thru |  |  | 4+/4- | Pass thru |  |  |
| Pins  | Bi-Amp  | Tri-Amp   |           |         |       |    |    |       |    |     |       |    |     |       |    |    |  |            |  |            |  |       |     |       |     |       |           |       |           |       |           |  |  |       |           |  |  |
| 1+/1-   | NC  | NC  |           |         |       |    |    |       |    |     |       |    |     |       |    |    |  |            |  |            |  |       |     |       |     |       |           |       |           |       |           |  |  |       |           |  |  |
| 2+/2-   | NC  | LF2   |           |         |       |    |    |       |    |     |       |    |     |       |    |    |  |            |  |            |  |       |     |       |     |       |           |       |           |       |           |  |  |       |           |  |  |
| 3+/3-   | LF  | LF1   |           |         |       |    |    |       |    |     |       |    |     |       |    |    |  |            |  |            |  |       |     |       |     |       |           |       |           |       |           |  |  |       |           |  |  |
| 4+/4-   | HF  | HF  |           |         |       |    |    |       |    |     |       |    |     |       |    |    |  |            |  |            |  |       |     |       |     |       |           |       |           |       |           |  |  |       |           |  |  |
| Pins (NL8)  |   | Pins (NL4)  |           |         |       |    |    |       |    |     |       |    |     |       |    |    |  |            |  |            |  |       |     |       |     |       |           |       |           |       |           |  |  |       |           |  |  |
| 1+/1-   | Sub   | 1+/1-   | Sub       |         |       |    |    |       |    |     |       |    |     |       |    |    |  |            |  |            |  |       |     |       |     |       |           |       |           |       |           |  |  |       |           |  |  |
| 2+/2-   | Pass thru   | 2+/2-   | Pass thru |         |       |    |    |       |    |     |       |    |     |       |    |    |  |            |  |            |  |       |     |       |     |       |           |       |           |       |           |  |  |       |           |  |  |
| 3+/3-   | Pass thru   |   |           |         |       |    |    |       |    |     |       |    |     |       |    |    |  |            |  |            |  |       |     |       |     |       |           |       |           |       |           |  |  |       |           |  |  |
| 4+/4-   | Pass thru   |   |           |         |       |    |    |       |    |     |       |    |     |       |    |    |  |            |  |            |  |       |     |       |     |       |           |       |           |       |           |  |  |       |           |  |  |
| Attachment Points   | Integral, side plate adjustable rigging system, vertical splay adjustable in 1° increments from 0° – 10°  | Integral, non-adjustable (straight array only)                      |           |         |       |    |    |       |    |     |       |    |     |       |    |    |  |            |  |            |  |       |     |       |     |       |           |       |           |       |           |  |  |       |           |  |  |
| Weight (Net/Shipping)                                     | 37 lb (16.8 kg) / 45 lb (20.45 kg)  | 111 lb (50.4 kg) / 121 lb (55 kg)                                   |           |         |       |    |    |       |    |     |       |    |     |       |    |    |  |            |  |            |  |       |     |       |     |       |           |       |           |       |           |  |  |       |           |  |  |
| Dimensions (HWD)  | 11.8" x 27" x 13.4" (300 mm x 686 mm x 340 mm)  | 22.1" x 27.6" x 30.3" (562 mm x 702 mm x 771 mm)                    |           |         |       |    |    |       |    |     |       |    |     |       |    |    |  |            |  |            |  |       |     |       |     |       |           |       |           |       |           |  |  |       |           |  |  |
| Accessories Available                                     | <p>FB2082-i: Fly-bar for WL2082-i, WL118-sw and WL115-sw. Available in black or white.</p> <p>EB2082-i: Extension bar, allows WL118-sw or WL115-sw to be suspended behind WL2082-i. Available in black or white.</p> <p>PB2082-i: Pullback bar for WL2082-i. For use when pulling back the bottom of the array is necessary to achieve the desired angle. Available in black or white.</p> <p>AB2082-i: Angle bracket, allows greater vertical splay between WL2082-i and WL118-sw or WL115-sw enclosures in ground stacked configurations. Available in black. Requires two brackets per array, sold individually.</p> <p>GS115-sw: Ground stack kit for WL118-sw or WL115-sw.</p> <p>QRP-KIT-1: Kit of four (4) Quick Release Pins for use in lieu of included bolts.</p> |   |           |         |       |    |    |       |    |     |       |    |     |       |    |    |  |            |  |            |  |       |     |       |     |       |           |       |           |       |           |  |  |       |           |  |  |

<sup>1</sup>) 2 hours, IEC specified noise

Specifications subject to change without notice.

# ILA System v2

## Dimensions

WL2082-i

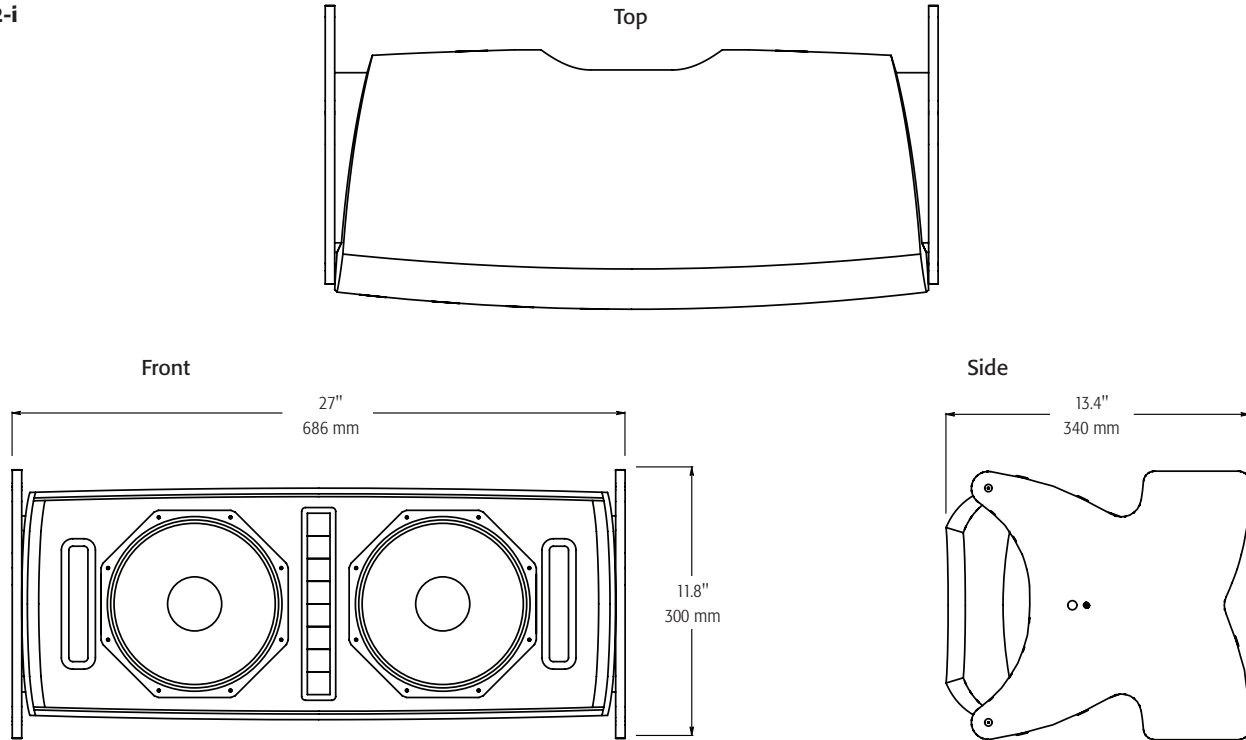

WL118-sw

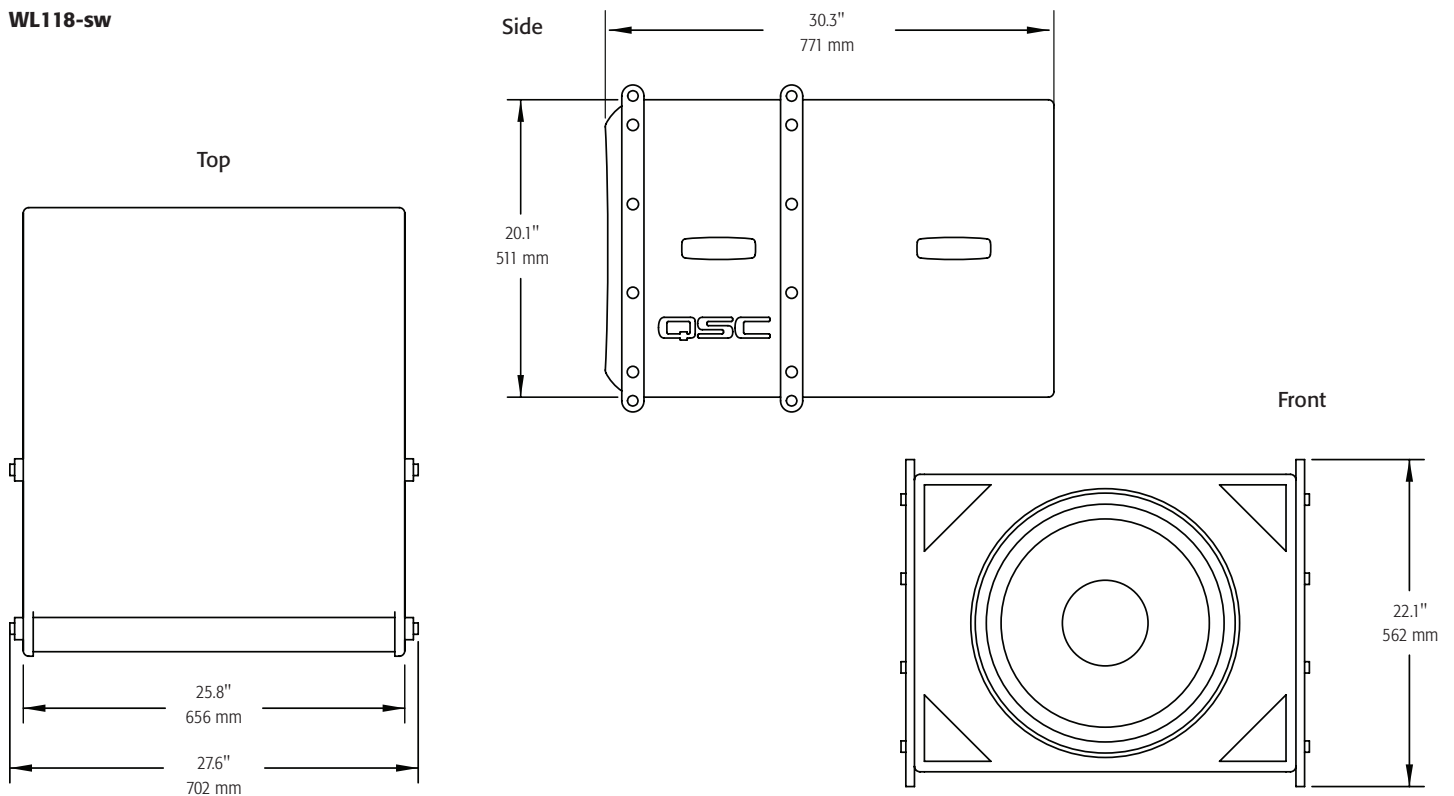

Specifications subject to change without notice.



QSC, the QSC logo and BASIS are registered trademarks of QSC Audio Products, LLC in the U.S. Patent and Trademark office and other countries. Intrinsic Correction is a trademark of QSC Audio Products, LLC. All other trademarks are the property of their respective owners. US Pat. 7,177,437. Other patents may apply or be pending.

1675 MacArthur Boulevard • Costa Mesa, CA 92626 • Ph: 800/854-4079 or 714/957-7100 • Fax: 714/754-6174

ILA System v2 Spec Sheet 01/08/09

**QSC**  
qscaudio.com