

ControlSpace® WP22BU-D 2-in/2-out Dante™ Wall Plate

BOSE

TECHNICAL DATA SHEET

Product Description

The Bose® ControlSpace® WP22BU-D Dante wall plate is a cost effective multi-I/O wall box. The WP22BU-D features a balanced mic/line XLR input and a balanced XLR line output. Unbalanced options include two RCA line-level inputs, a 3.5mm TRS line-level input and a 3.5mm TRS line-level output. The WP22BU-D is designed to fit into most dual gang US junction boxes and is PoE enabled, so all connectivity (power and data) is provided by a single CAT-5 cable. The size of the WP22BU-D makes it easy to put Dante connectivity close to analog devices, helping to reduce costly and interference-prone analog wiring.

Key Features

- One balanced XLR mic/line input, one stereo (summed to mono) unbalanced input
- One balanced XLR line output and one mono unbalanced 3.5mm output — or one stereo unbalanced 3.5mm output
- 802.3af compliant PoE powered to work with any compliant PoE network switch
- Three gain levels are available on the XLR input with +48VDC Phantom power – all adjustable via ControlSpace Designer™ software
- ID indicator allows easy identification of which WP22BU-D is communicating with ControlSpace Designer software
- RCA inputs (mono-summed) and 3.5 mm input (mono-summed) can be selected via software, individually or summed (see Audio Flow diagram)

Technical Specifications

Audio Inputs	
Input Channels	Two (2) analog, balanced (XLR) and unbalanced (RCA and/or 3.5mm)
Connectors	One (1) XLR, one (1) RCA pair, one (1) 3.5mm TRS
Phantom Power	+48VDC, software selectable (XLR input only)
Gain Settings	0 / +25 / +40 dB, software selectable (XLR input only)
Input Impedance	> 1.8 kΩ at any gain setting
Equivalent Input Noise	-115 dBu (+40 dB gain)
Maximum Input Level	+12 dBu @ 0 dB gain
Audio Outputs	
Output Channels	Two (2) analog, balanced (XLR) and unbalanced 3.5 mm, with automatic muting on loss of Dante signal
Connectors	One (1) XLR, one (1) 3.5mm TRS
Output Noise	< -90 dBu
Maximum Output Level	+12 dBu
Software Application	
ControlSpace® Designer™ software v4.2 or later	
General	
Digital Conversion	48 kHz / 24-bit
System THD	< 0.01 % at any gain, input signal 3dB below maximum
PoE class	Class 0 802.3af PoE PD compliant
Certifications	FCC Part 15 Class A, CE (EN 55022 Class A)
Dimensions	2.75" H x 3.60" W x 1.88" D (70 mm x 91 mm x 48 mm)
Operating temperature	32 °F – 104 °F (0 °C – 40 °C)
Product code	738678-0010



Applications

Convenient, wall-mounted mic/line I/O drops for:

- Hotel ballrooms
- Conference/meeting centers
- Conference rooms
- Sports facilities
- Convention centers
- Religious and worship facilities
- Retrofit applications using existing networking cables

ControlSpace® WP22BU-D Dante™ Wall Plate



Connector Panel

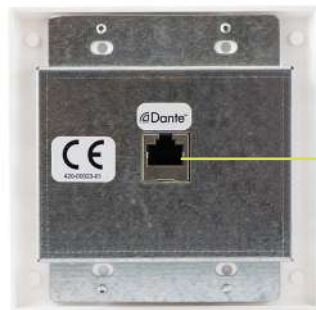
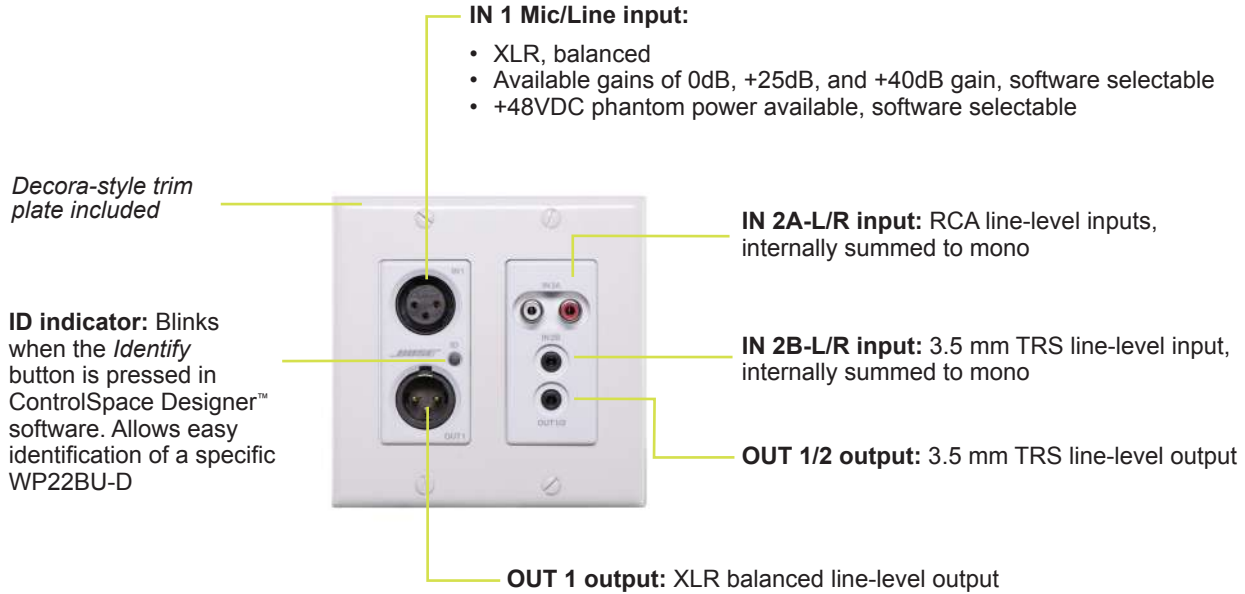

Dante™ / PoE network connector:
100 Mbps Dante Ethernet RJ-45 network connection

WP22BU-D Audio Flow Diagram

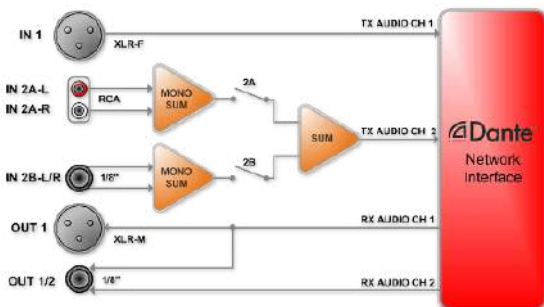

ControlSpace Designer™ software interface

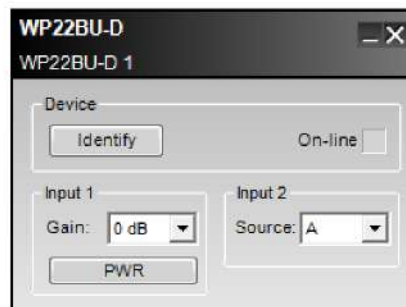

Dante™ is a trademark of Audinate Pty Ltd.